

FIGURE No. 7168SS



**RESILIENT SEAT GATE VALVE
WITH CLASS 250 END FLANGES
SIZES 2.5" - 12"
DUCTILE IRON MODEL KS-300**

KENNEDY VALVE

UL
LISTED
(2 1/2" - 8")

Generic Valve available in 10" - 12"

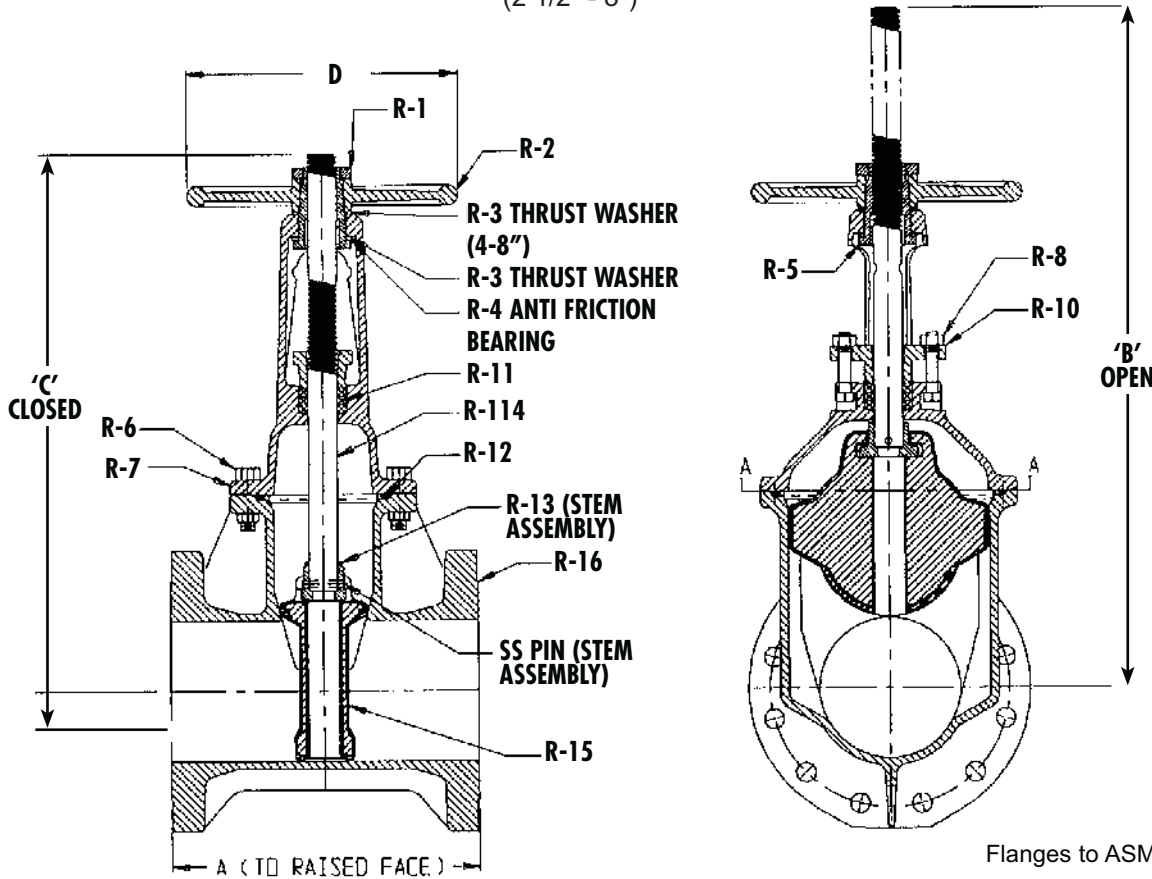

Flanges to ASME B16.1 Class 250

Item	Description	#req'd	Material	Specification
R-1	Handwheel Nut	1	Bronze	ASTM B584 C83600
R-2	Handwheel	1	Cast Iron	ASTM A-126 Class B
R-3 U/L	Thrust Washer	1(2.5-3"); 2(4-12")	Bronze	ASTM B836
R-4	Anti-Friction Bearing	1	Nylatron Sizes 3"-12"	
R-5	Yoke Nut		Bronze	ASTM B584 C83600
R-6	Hex. Head Bolts		Stainless Steel	ASTM F593C
	Hex. Nuts		Stainless Steel	ASTM F593C/F594
R-7	Cover	1	Ductile Iron	ASTMA536
R-8	Hex. Nuts	2	Brass	ASTMA563
	Sq. Head Bolts	2	Zinc Plated Steel	ASTM A307
R-10	Gland	1	Ductile Iron	ASTM A536
R-11	Packing		Lubricated Fiber	
R-12	O'Ring	1	BUNA-N	
R-13	O'Ring Stem (Assy)	1	BUNA-N assy	
R-14	STEM	1	Brass B16	
R-15	Wedge Disc	1	Ductile Iron (6 & 8)	ASTM A536
			Gray Iron (3, 4, 10 & 12)	ASTM 126 Class B
			EPDM	
R-16	Flanged Body	1	Ductile Iron	ASTMA536

Size	A	B	C	D	# Turns to Open	Approx Weight (lbs)
2.5"/3"	8.63"	18 7/8"	15 5/8"	10"	10	80
4"	11.75"	22 3/4"	18 1/4"	10"	13 1/2	115
6"	13.63"	30 1/8"	23 3/4"	12"	19 1/2	180
8"	14.13"	37 3/4"	29 1/4"	14"	25 1/2	275
10"	14.31"	45 3/4"	35 3/8"	18"	31	447
12"	15.37"	53 1/8"	40 5/8"	18"	37	580

* 3" size available with 2.5" bolt pattern and 3/4"-10 tapped (threaded) holes

Working Pressure:	300 PSI
Hydrostatic Seat Test:	450 PSI
Hydrostatic Shell Test:	600 PSI

FIGURE No. 7058

Item	Description	# Req'd	Material
R-1	Hex. Head Bolt	1	Stainless Steel ASTM F593C
R-2	Flat Washer	1	Commercial Steel
R-3	Operating Nut	1	Cast Iron ASTM A-126 Class B
R-3	Hand Wheel	1	Cast Iron ASTM A-126 Class B
R-4	Stuffing Box Bolts	2	Stainless Steel ASTM F593C
R-5	Hex. Nuts	2	Stainless Steel ASTM F594
R-6	Stuffing Box	1	Ductile Iron ASTM A536 Grade 70-50-5
R-7	'O' Ring (Stem)	3	BUNA-N
R-8	'O' Ring (St. Box)	1	BUNA N
R-9	Thrust Washer	1	2" & 2.5" DELRIN
		2	3" & 12"
R-10	Stem	1	Bronze ASTM B 584, C86700
R-11	Hex. Head Bolts		Stainless Steel
R-12	Hex. Nuts		Stainless Steel
R-13	Cover	1	Ductile Iron
R-14	Stem Nut	1	Bronze ASTM B-584\C83600
R-15	'O'Ring (cover)	1	BUNA-N
R-16	Wedge Disc	1	3"-4": Gray Iron, 6"-12": Ductile EPDM Resilient Molded Wedge
R-17	Body	1	Ductile Iron
R-18	(Optional Post Adaptor Plate)	1	Cast Iron ASTM A126 Class B



(2 1/2" - 8")

**RESILIENT SEAT GATE VALVE
WITH CLASS 250 END FLANGES
SIZES 2.5" - 12"
DUCTILE IRON MODEL KS-300**

KENNEDY VALVE

Generic Valve available in 10" - 12"

- Coating: Heat Fused Epoxy
- Bolts: Strength to meet ASTM A307
- Flanges: ASME B16.1 CLASS 250

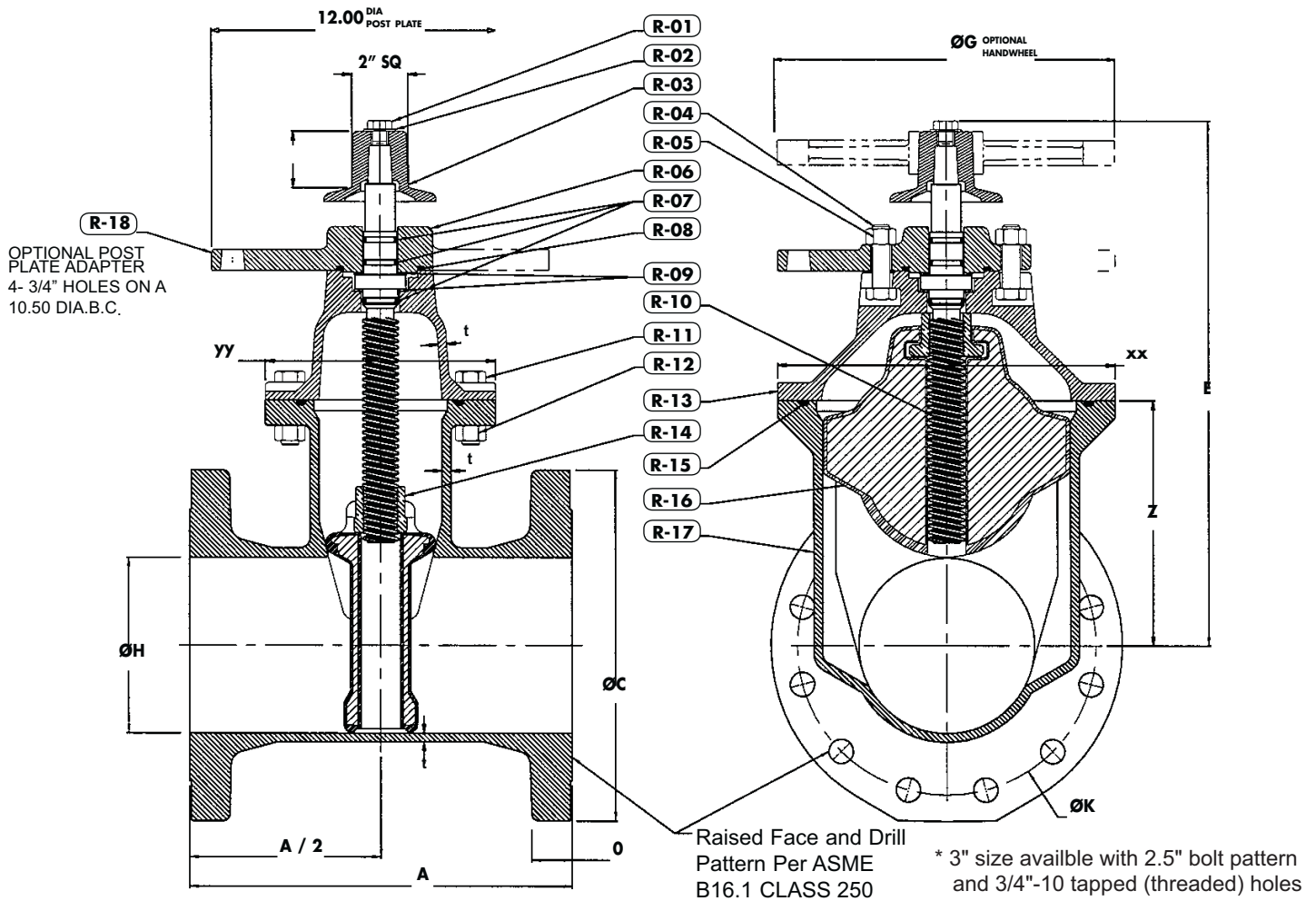

REFERENCE DIMENSIONS			
Nominal Size In's	xx	yy	z
* 2.5	7.50	6.75	5.00
3	7.50	6.75	5.00
4	9.50	7.00	6.00
6	12.00	8.00	8.75
8	14.88	9.00	10.38
10	18.38	10.75	12.13
12	20.81	11.25	14.13

Nominal Size (inch)	Clear Dia H	No. of Turns to open	Valve Dimensions			Flanges & Flange Drilling					
			A	E	H'Wheel O.D. GØ	Flange O.D. CØ	Flange Thick O	B.C. Ø K	Size of Bolts FØ	No. of Bolts F	Approx Weight (lbs)
* 2.5	3.00"	5	8.36	-	-	8.25	1.13	5.88	3/4	8	78
3	3.00"	10	8.63	-	-	8.25	1.13	6.63	3/4	8	78
4	4.25"	13	11.75	14.75"	10.00"	10.00	1.25	7.88	3/4	8	99
6	6.25"	19	13.63	19.00"	12.00"	12.50	1.44	10.62	3/4	12	166
8	8.25"	25	14.13	22.50"	14.00"	15.00	1.63	13.00	7/8	12	253
10	10.25"	31	14.31	26.50"	18.00"	17.50	1.88	15.25	1	16	415
12	12.25"	37	15.37	30.00"	18.00"	20.50	2.00	17.75	1 1/8	16	532



Kennedy Valve

A DIVISION OF McWANE, INC.

www.kennedyvalve.com

1021 E. Water Street • Elmira, New York 14901
P.O. Box 981
PHONE: (607) 734-2211 • FAX: 1-800-952-4771

Updated 02/22/11