

**KENNEDY AWWA DBL. DISC PARALLEL SEAT IBBM GATE VALVES**

KENNEDY VALVE

**KENNEDY VALVE AWWA Dbl. Disc Parallel Seat IBBM Gate Valves Meet or Exceed the Requirements of AWWA C500**

Size Range	2"-48"	
	Water working Pressure psi	Hydrostatic Test psi
2"-12"	200	400
14"-48"	150	300

Available in either, NRS, or OS&Y.

**Available End Connections & Size Range Figure No.**

Fig.-NRS	2"-48"	F-5070
Fig.-OS&Y	14"-36"	F-5072
M.J.	2"-36"	F-5065
M J Cutting End	4"-12"	F-5067
Fig. & M.J.	4"-36"	F-5066
Push-on Ends for PVC	2"-10"	F-5085

**Accessories**

Floorstands (NRS & R.S.)	By-Pass Valves
Needle & Slot (Navy) Indicators	Enclosed Gearing(Grease Case)
Electric Motors	Position Indicators
2" Sq. Operating Nuts	Tracks, Rollers, & Scrapers for
Chainwheels	Valves 14" or larger
"T" Handles	Horizontal Position in Horizontal Line
Stem Guides	Handwheels
Indicator Posts	Extension Stems

Floor Boxes

\*Note: Call Factory For Special Applications

# AWWA DOUBLE DISC GATE VALVES PARTS LIST

## KENNEDY VALVE

\*Recommended Spare Parts

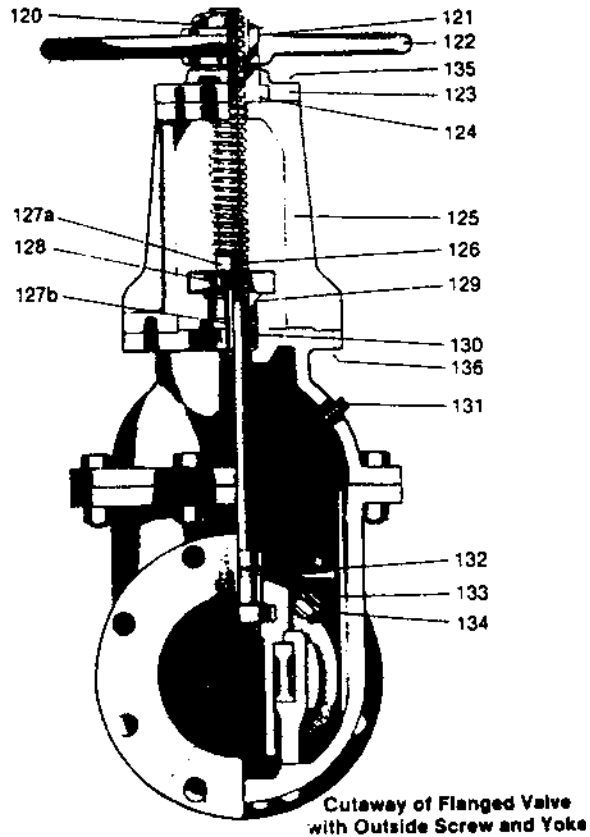
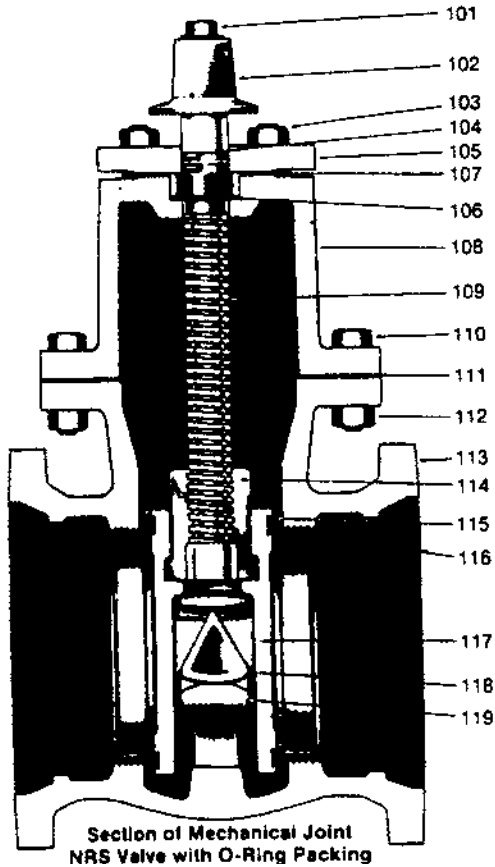

DET.	QTY.	DESCRIPTION	MATERIAL
101	1	Cap Screw	Steel
102	1	Operating Nut	Cast Iron
*103		O-Ring Plate Bolts & Nuts	Steel
*104	2	O-Rings	Rubber
105	1	O-Ring Plate	Cast Iron
106	1	Low Torque Bearing	
*107	1	Stuffing Box Gasket	
108	1	Cover	Cast Iron
*109	1	Non-Rising Stem	Bronze
*110		Neck Flange Bolts	Steel – Rust-Proofed
*111	1	Neck Flange Gasket	Composition
*112		Neck Flange Bolt Nuts	Steel
113	1	Body	Cast Iron
*114	1	Gate Nut	Bronze
115	2	Gate Ring	
116	2	Case Ring	Bronze
*117	2	Gate	Cast Iron
*118	2	Wedge	Bronze
*119	2	Hook	Cast Iron

DET.	QTY.	DESCRIPTION	MATERIAL
*120	1	Hold Down Nut	Bronze
121	1	Handwheel Key	Steel
122	1	Handwheel	Cast Iron
123	1	OS&Y Retainer Plate	Cast Iron
*124	1	OS&Y Stem Nut	Bronze
125	1	OS&Y Yoke	Cast Iron
*126	1	Rising Stem	Bronze
127A	2	Follower Nuts	Bronze
127B	2	Follower Studs	Steel – Rust-Proofed
128	1	Follower Plate	Cast Iron
129	1	Follower Gland	Bronze
*130		Packing	Acrylic Graphite
131	1	Test Plug	Teflon-Coated Steel
*132	1	Stem Nut Pin	Bronze
*133	4	Pegs	Bronze
*134	2	Straps	*Stainless or Bronze
*135		OS&Y Cap Screws	Stainless 10" & 12" Only Steel – Rust-Proofed
136		OS&Y Yoke Bolts & Nuts	Steel – Rust-Proofed

# KENNEDY AWWA GATE VALVES UNDERGROUND AND PLANT PIPING SYSTEMS

## KENNEDY VALVE

VALVE SIZE	A	B	G	J	K	M <sub>1</sub>	P	Q	R	S	U	Y	Z	AA	BB	DD	GG	HH	LL	Turns to Open	Diam. of Stem
2	7	—	10 <sup>1</sup> / <sub>4</sub>	3 <sup>1</sup> / <sub>4</sub>	—	10 <sup>1</sup> / <sub>4</sub>	3	14	11 <sup>1</sup> / <sub>2</sub>	7 <sup>1</sup> / <sub>4</sub>	—	—	—	—	—	—	—	—	5 <sup>1</sup> / <sub>8</sub>	5	7 <sup>7</sup> / <sub>8</sub>
2 <sup>1</sup> / <sub>4</sub>	7 <sup>1</sup> / <sub>2</sub>	—	10 <sup>1</sup> / <sub>4</sub>	3 <sup>1</sup> / <sub>4</sub>	—	10 <sup>1</sup> / <sub>4</sub>	—	—	—	7 <sup>1</sup> / <sub>4</sub>	—	—	—	—	—	—	—	—	—	5	7 <sup>7</sup> / <sub>8</sub>
2 <sup>1</sup> / <sub>2</sub>	7 <sup>1</sup> / <sub>2</sub>	—	11 <sup>3</sup> / <sub>8</sub>	—	—	11 <sup>3</sup> / <sub>8</sub>	3 <sup>7</sup> / <sub>8</sub>	20 <sup>1</sup> / <sub>4</sub>	12 <sup>1</sup> / <sub>2</sub>	7 <sup>1</sup> / <sub>4</sub>	—	—	—	—	—	—	—	—	—	6	7 <sup>7</sup> / <sub>8</sub>
3	8	—	12 <sup>1</sup> / <sub>4</sub>	3 <sup>1</sup> / <sub>2</sub>	—	12 <sup>1</sup> / <sub>2</sub>	3 <sup>3</sup> / <sub>8</sub>	20 <sup>1</sup> / <sub>4</sub>	16 <sup>3</sup> / <sub>4</sub>	7 <sup>1</sup> / <sub>4</sub>	—	—	—	—	—	—	—	—	5 <sup>3</sup> / <sub>4</sub>	7	7 <sup>7</sup> / <sub>8</sub>
4	9	—	14	4 <sup>3</sup> / <sub>4</sub>	5 <sup>1</sup> / <sub>4</sub>	14	4 <sup>1</sup> / <sub>2</sub>	24	19 <sup>3</sup> / <sub>4</sub>	10	—	—	—	—	—	—	—	—	6 <sup>7</sup> / <sub>8</sub>	15	1 <sup>1</sup> / <sub>8</sub>
5	10	—	15 <sup>1</sup> / <sub>2</sub>	—	—	15 <sup>1</sup> / <sub>2</sub>	5 <sup>1</sup> / <sub>4</sub>	27 <sup>1</sup> / <sub>4</sub>	21 <sup>3</sup> / <sub>4</sub>	10	—	—	—	—	—	—	—	—	8	21	1 <sup>1</sup> / <sub>8</sub>
6	10 <sup>1</sup> / <sub>2</sub>	—	18	5 <sup>1</sup> / <sub>4</sub>	6 <sup>1</sup> / <sub>2</sub>	18	6 <sup>1</sup> / <sub>4</sub>	31 <sup>1</sup> / <sub>2</sub>	24 <sup>3</sup> / <sub>4</sub>	12	—	—	—	—	—	—	—	—	8	21	1 <sup>1</sup> / <sub>4</sub>
8	11 <sup>1</sup> / <sub>2</sub>	—	22	6 <sup>1</sup> / <sub>2</sub>	7	22	6 <sup>1</sup> / <sub>4</sub>	40 <sup>1</sup> / <sub>2</sub>	31 <sup>1</sup> / <sub>2</sub>	14	—	—	—	—	—	—	—	—	9	27	1 <sup>3</sup> / <sub>8</sub>
10	13	—	25 <sup>5</sup> / <sub>8</sub>	6 <sup>3</sup> / <sub>4</sub>	7 <sup>1</sup> / <sub>4</sub>	25 <sup>5</sup> / <sub>8</sub>	6 <sup>1</sup> / <sub>2</sub>	47 <sup>1</sup> / <sub>4</sub>	36 <sup>1</sup> / <sub>4</sub>	18	—	8	—	—	—	—	—	9 <sup>7</sup> / <sub>8</sub>	—	33	1 <sup>1</sup> / <sub>2</sub>
12	14	—	29 <sup>1</sup> / <sub>8</sub>	7	7 <sup>3</sup> / <sub>4</sub>	29 <sup>1</sup> / <sub>8</sub>	—	58 <sup>3</sup> / <sub>8</sub>	45 <sup>3</sup> / <sub>8</sub>	18	—	8	—	18	40 <sup>3</sup> / <sub>4</sub>	12	38 <sup>1</sup> / <sub>2</sub>	31 <sup>5</sup> / <sub>8</sub>	10 <sup>1</sup> / <sub>2</sub>	39	1 <sup>1</sup> / <sub>2</sub>
14	15 <sup>3</sup> / <sub>4</sub>	23	36 <sup>1</sup> / <sub>2</sub>	7 <sup>1</sup> / <sub>4</sub>	—	39 <sup>3</sup> / <sub>4</sub>	—	68	53	22	19 <sup>1</sup> / <sub>4</sub>	8	31 <sup>7</sup> / <sub>8</sub>	18	45	12	42 <sup>3</sup> / <sub>4</sub>	35 <sup>7</sup> / <sub>8</sub>	11 <sup>1</sup> / <sub>2</sub>	45	1 <sup>7</sup> / <sub>8</sub>
16	17	23	40 <sup>3</sup> / <sub>4</sub>	9 <sup>1</sup> / <sub>4</sub>	—	43 <sup>1</sup> / <sub>2</sub>	—	75 <sup>3</sup> / <sub>4</sub>	58 <sup>3</sup> / <sub>4</sub>	22	20 <sup>1</sup> / <sub>2</sub>	8	33 <sup>3</sup> / <sub>8</sub>	18	49	12	46 <sup>3</sup> / <sub>4</sub>	39 <sup>3</sup> / <sub>4</sub>	15 <sup>3</sup> / <sub>8</sub>	52	1 <sup>7</sup> / <sub>8</sub>
18	19	24	43 <sup>1</sup> / <sub>4</sub>	9 <sup>1</sup> / <sub>4</sub>	—	46	—	82 <sup>1</sup> / <sub>2</sub>	63 <sup>1</sup> / <sub>2</sub>	26	22 <sup>1</sup> / <sub>2</sub>	8	36 <sup>3</sup> / <sub>8</sub>	18	52 <sup>1</sup> / <sub>8</sub>	12	50	42 <sup>7</sup> / <sub>8</sub>	16 <sup>1</sup> / <sub>2</sub>	58	2 <sup>1</sup> / <sub>8</sub>
20	20	24	47 <sup>1</sup> / <sub>4</sub>	10	—	50	—	90 <sup>1</sup> / <sub>4</sub>	69 <sup>1</sup> / <sub>4</sub>	26	24	8	40 <sup>1</sup> / <sub>2</sub>	18	55 <sup>3</sup> / <sub>4</sub>	12	53 <sup>3</sup> / <sub>8</sub>	46 <sup>1</sup> / <sub>2</sub>	18 <sup>3</sup> / <sub>8</sub>	64	2 <sup>1</sup> / <sub>8</sub>
24	23	28 <sup>1</sup> / <sub>2</sub>	55	16	—	56 <sup>3</sup> / <sub>4</sub>	—	107	82	30	28	8	46	18	62 <sup>1</sup> / <sub>8</sub>	12	60	52 <sup>7</sup> / <sub>8</sub>	22	76	2 <sup>1</sup> / <sub>2</sub>
30	25	32 <sup>1</sup> / <sub>2</sub>	64 <sup>3</sup> / <sub>4</sub>	12 <sup>1</sup> / <sub>2</sub>	—	66 <sup>1</sup> / <sub>2</sub>	—	128 <sup>1</sup> / <sub>4</sub>	97	30	31 <sup>1</sup> / <sub>2</sub>	10	54 <sup>1</sup> / <sub>2</sub>	18	76 <sup>3</sup> / <sub>4</sub>	15 <sup>1</sup> / <sub>2</sub>	72 <sup>1</sup> / <sub>8</sub>	66	—	63	2 <sup>3</sup> / <sub>4</sub>
36	27	36	75 <sup>3</sup> / <sub>8</sub>	23 <sup>3</sup> / <sub>4</sub>	—	77 <sup>3</sup> / <sub>8</sub>	—	147 <sup>1</sup> / <sub>2</sub>	110	36	40	13 <sup>3</sup> / <sub>8</sub>	68 <sup>1</sup> / <sub>8</sub>	22	88 <sup>3</sup> / <sub>8</sub>	21 <sup>1</sup> / <sub>2</sub>	81 <sup>1</sup> / <sub>8</sub>	72 <sup>3</sup> / <sub>8</sub>	—	75	3
42	34	34	—	—	—	—	—	—	—	30	47	10	77 <sup>1</sup> / <sub>2</sub>	30	106 <sup>3</sup> / <sub>8</sub>	27	105 <sup>1</sup> / <sub>2</sub>	97	—	88	3 <sup>1</sup> / <sub>2</sub>
48	45 <sup>1</sup> / <sub>2</sub>	45 <sup>1</sup> / <sub>2</sub>	—	—	—	—	—	—	—	30	54 <sup>1</sup> / <sub>2</sub>	11 <sup>1</sup> / <sub>4</sub>	87 <sup>1</sup> / <sub>2</sub>	30	120 <sup>5</sup> / <sub>8</sub>	27	119	108	—	100	4

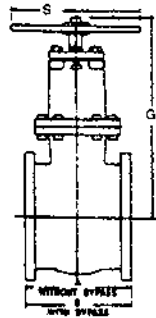

C561/F-5070  
Flanged Ends

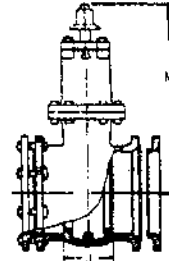

C571/F-5065  
Mechanical Joint  
C572/F-5066

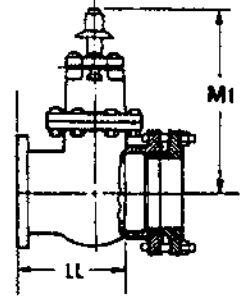

Flanged and  
Mechanical Joint Ends  
C901/F-5080

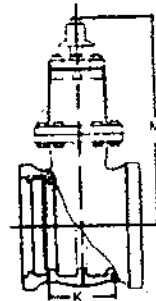

Push-On Ends  
For Cast Iron Pipe  
C950/F-5093

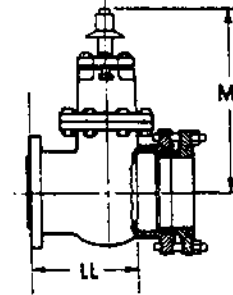

Mechanical Joint  
Tapping Valve  
C597/F-5085

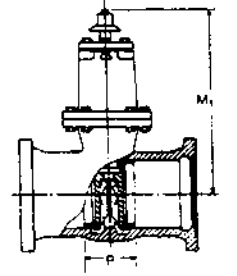

Push-On Ends  
For PVC Pipe  
C566/F-5072

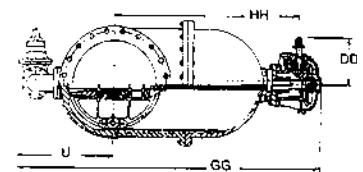
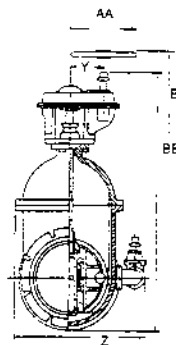

URNS TO OPEN ARE FOR VALVES WITHOUT GEARING  
DIMENSIONS-INCHES

FLANGES ARE FACED AND DRILLED TO ANSI 125 POUND  
TEMPLATE, UNLESS OTHERWISE SPECIFIED

**2"-12" FLANGED END  
C561/F-5070 GATE VALVE**

KENNEDY VALVE

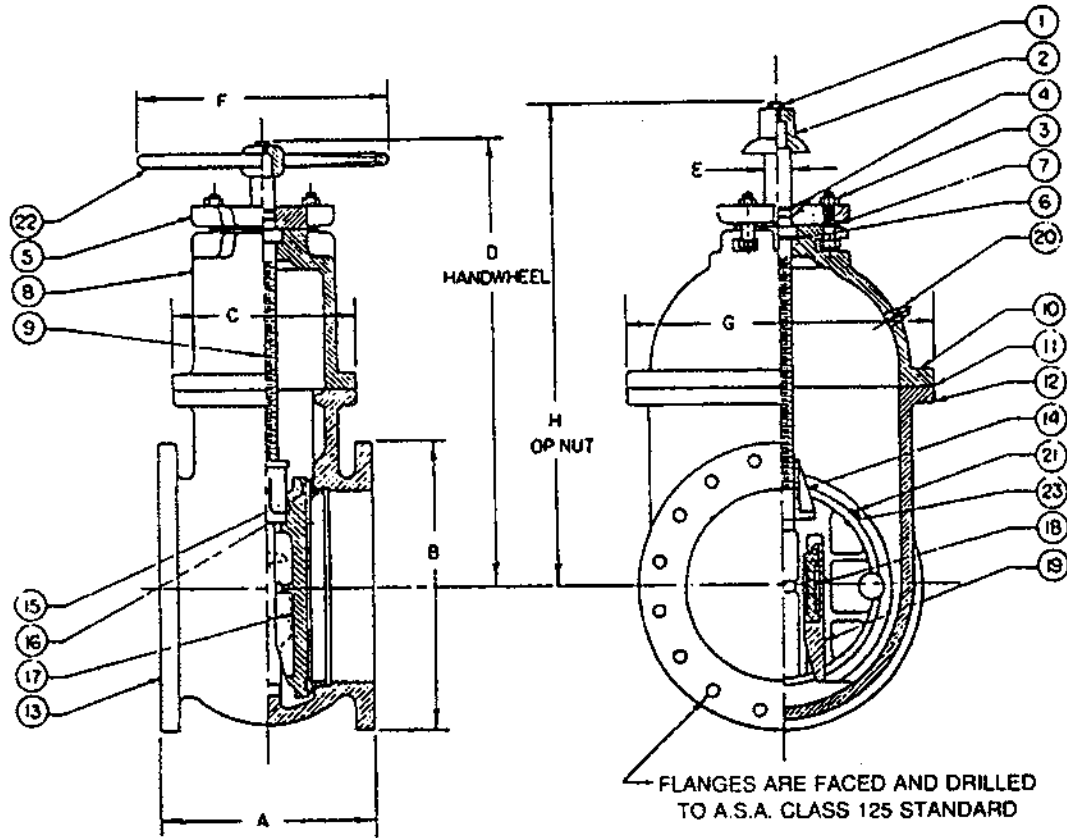

SEQ.	QTY.	DESCRIPTION	MATERIAL
1	1	Capscrew	Steel
2	1	Operating Nut	Cast Iron
3		Bolts & Nuts	Stainless Steel
4	2	O-Rings	Rubber
5	1	O-Ring Plate	Cast Iron
6	1	Low Torque Bearing	Delrin 1
7	1	Stuffing Box Gasket	Composition
8	1	Cover	Cast Iron
9	1	Non-Rising Stem	Bronze
10		Neck-Flange Bolts	Stainless Steel
11	1	Neck-Flange Gaskets	Composition
12		Neck-Flange Nuts	Stainless Steel
13	1	Body	Cast Iron
14	1	Gate Nut	Bronze
15	2	Gate Ring	Bronze
16	2	Case Ring	Bronze
17	2	Gate	Cast Iron
18	2	Wedge	Bronze
19	2	Hook	Cast Iron
20	1	Pipe Plug	Cast Iron
21	4	Pegs – On 10", 12" & 14" Valves	Bronze
22	1	Handwheel	Cast Iron
23	2	Straps – On 10", 12" & 14" Valves	Stainless Steel

VALVE SIZE	A	B	C	D	E	F	G	H	Weight	Turns to Open
2	7	6	5	11 <sup>3</sup> / <sub>4</sub>	7 <sup>7</sup> / <sub>8</sub>	7 <sup>1</sup> / <sub>4</sub>	5 <sup>7</sup> / <sub>8</sub>	11 <sup>3</sup> / <sub>4</sub>	30	5
2 <sup>1</sup> / <sub>2</sub>	7 <sup>1</sup> / <sub>2</sub>	7	5 <sup>1</sup> / <sub>8</sub>	13	7 <sup>7</sup> / <sub>8</sub>	7 <sup>1</sup> / <sub>4</sub>	6 <sup>3</sup> / <sub>8</sub>	13	30	6
3	8	7 <sup>1</sup> / <sub>2</sub>	5 <sup>1</sup> / <sub>2</sub>	14	7 <sup>7</sup> / <sub>8</sub>	7 <sup>1</sup> / <sub>4</sub>	7 <sup>7</sup> / <sub>8</sub>	14	50	7
4	9	9	7	15 <sup>1</sup> / <sub>4</sub>	1 <sup>7</sup> / <sub>8</sub>	10	9	15 <sup>1</sup> / <sub>4</sub>	90	15
5	10	10	7 <sup>3</sup> / <sub>4</sub>	16 <sup>3</sup> / <sub>4</sub>	1 <sup>7</sup> / <sub>8</sub>	10	10 <sup>7</sup> / <sub>8</sub>	16 <sup>3</sup> / <sub>4</sub>	120	18
6	10 <sup>1</sup> / <sub>2</sub>	11	9	18 <sup>1</sup> / <sub>2</sub>	1 <sup>1</sup> / <sub>4</sub>	12	12 <sup>5</sup> / <sub>8</sub>	18 <sup>1</sup> / <sub>2</sub>	166	21
8	11 <sup>1</sup> / <sub>2</sub>	13 <sup>1</sup> / <sub>2</sub>	10	21 <sup>5</sup> / <sub>8</sub>	1 <sup>3</sup> / <sub>8</sub>	14	15 <sup>1</sup> / <sub>4</sub>	21 <sup>5</sup> / <sub>8</sub>	288	27
10	13	16	10 <sup>5</sup> / <sub>8</sub>	28 <sup>1</sup> / <sub>4</sub>	1 <sup>1</sup> / <sub>2</sub>	18	18 <sup>1</sup> / <sub>4</sub>	28 <sup>1</sup> / <sub>4</sub>	405	33
12	14	19	11 <sup>1</sup> / <sub>4</sub>	30 <sup>3</sup> / <sub>4</sub>	1 <sup>1</sup> / <sub>2</sub>	18	20 <sup>1</sup> / <sub>4</sub>	30 <sup>3</sup> / <sub>4</sub>	565	39

# 14"-36" FLANGED END C561/F-5070 GATE VALVE

KENNEDY VALVE

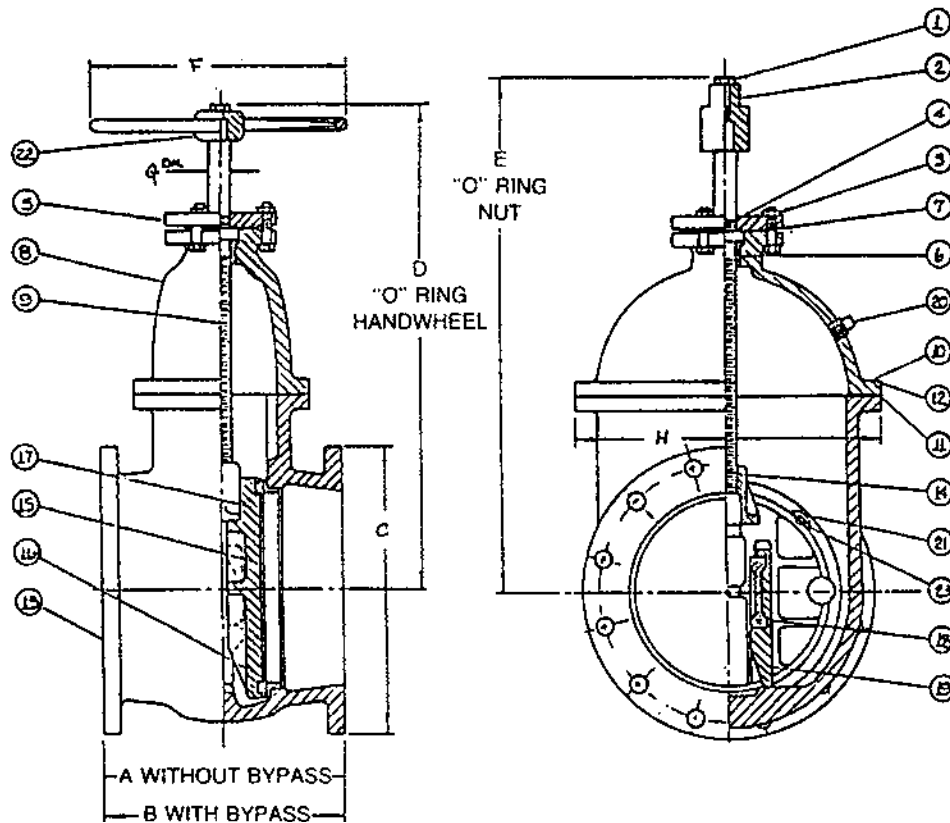

ITEM	QTY.	DESCRIPTION	MATERIAL
1	1	Capscrew	Steel
2	1	Operating Nut	Cast Iron
3		Bolts & Nuts	Stainless Steel
4	2	O-Rings	Rubber
5	1	O-Ring Plate	Cast Iron
6	1	Low Torque Bearing	Bronze
7	1	Stuffing Box Gasket	Composition
8	1	Cover	Cast Iron
9	1	Non-Rising Stem	Bronze B-584
10		Neck-Flange Bolts	Stainless Steel
11	1	Neck-Flange Gaskets	Composition
12		Neck-Flange Nuts	Stainless Steel
13	1	Body	Cast Iron
14	1	Gate Nut	Bronze
15	2	Gate Ring	Bronze
16	2	Case Ring	Bronze
17	2	Gate	Cast Iron
18	2	Wedge	Bronze
19	2	Hook	Cast Iron
20	1	Pipe Plug	Cast Iron
21	4	Pegs - On 10", 12" & 14" Valves	Bronze
22	1	Handwheel	Cast Iron
23	2	Straps - On 10", 12" & 14" Valves	Stainless Steel

VALVE SIZE	A	B	C	D	E	F	G	H	Weight	Turns to Open
14	15 <sup>3</sup> / <sub>4</sub>	23	21	36 <sup>1</sup> / <sub>2</sub>	38 <sup>3</sup> / <sub>4</sub>	22	1 <sup>7</sup> / <sub>8</sub>	23 <sup>3</sup> / <sub>8</sub>	876	45
16	17	23	23 <sup>1</sup> / <sub>2</sub>	40 <sup>3</sup> / <sub>4</sub>	43 <sup>1</sup> / <sub>2</sub>	22	1 <sup>7</sup> / <sub>8</sub>	25 <sup>3</sup> / <sub>4</sub>	1155	52
18	18	24	25	43 <sup>1</sup> / <sub>4</sub>	46	26	2 <sup>1</sup> / <sub>8</sub>	27 <sup>3</sup> / <sub>4</sub>	1460	58
20	20	24	27 <sup>1</sup> / <sub>2</sub>	47 <sup>1</sup> / <sub>4</sub>	50	26	2 <sup>1</sup> / <sub>8</sub>	32 <sup>7</sup> / <sub>8</sub>	1980	64
24	23	28 <sup>1</sup> / <sub>2</sub>	32	55	56 <sup>3</sup> / <sub>4</sub>	30	2 <sup>1</sup> / <sub>2</sub>	35 <sup>3</sup> / <sub>4</sub>	2730	76
30	25	32 <sup>1</sup> / <sub>2</sub>	38 <sup>3</sup> / <sub>4</sub>	64 <sup>3</sup> / <sub>4</sub>	66 <sup>1</sup> / <sub>2</sub>	30	2 <sup>3</sup> / <sub>4</sub>	45 <sup>3</sup> / <sub>4</sub>	4784	63
36	27	36	46	75 <sup>3</sup> / <sub>8</sub>	77 <sup>3</sup> / <sub>8</sub>	36	3	56 <sup>1</sup> / <sub>4</sub>	5301	75

## 2"-12" MECHANICAL JOINT C571/F-5065 GATE VALVE

KENNEDY VALVE

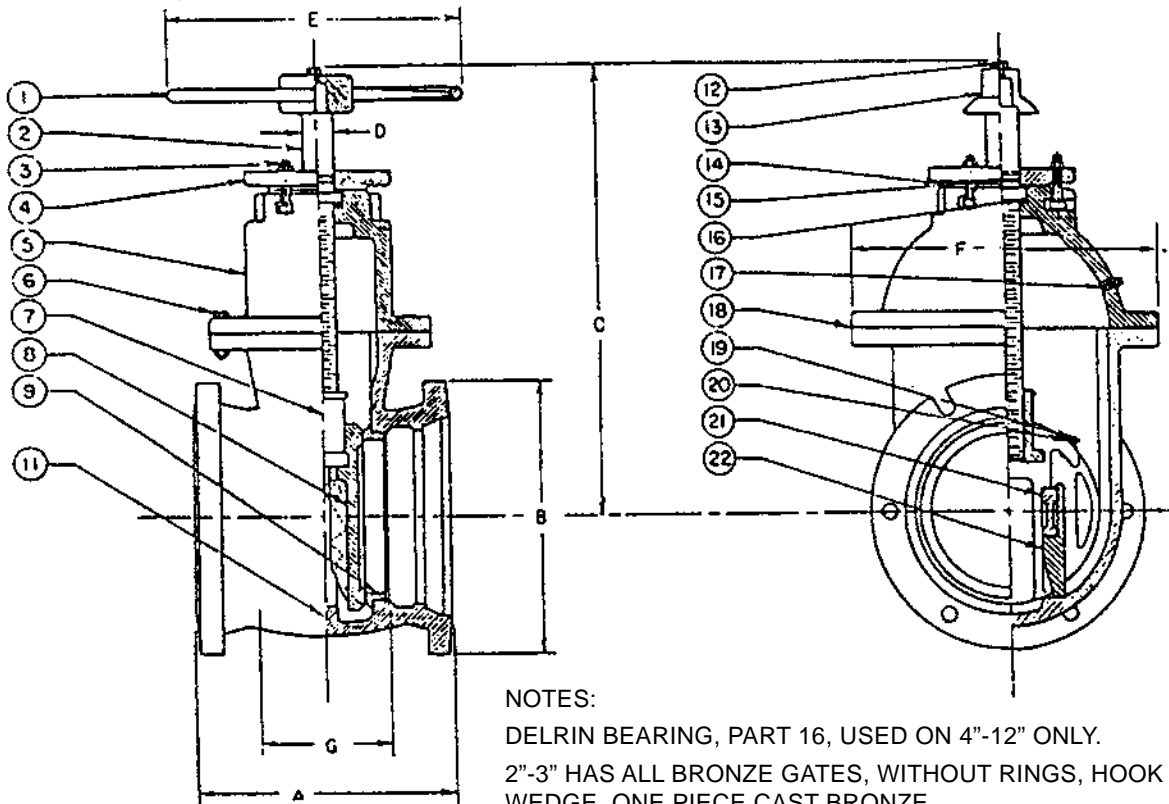

**NOTES:**

DELRIN BEARING, PART 16, USED ON 4"-12" ONLY.

2"-3" HAS ALL BRONZE GATES, WITHOUT RINGS, HOOK AND WEDGE. ONE PIECE CAST BRONZE.

CAPSCREW, STRAP, PARTS 19, 20, USED ON 10"-12" ONLY.

NOTE: MECH. JOINT ENDS MEET SPECS.  
A.S.A. A-21-11

VALVE SIZE	A	B	C	D	E	F	G	Weight	Turns to Open
2	8 <sup>1</sup> / <sub>4</sub>	4 <sup>1</sup> / <sub>2</sub>	10 <sup>1</sup> / <sub>4</sub>	7 <sup>7</sup> / <sub>8</sub>	7 <sup>1</sup> / <sub>4</sub>	5 <sup>7</sup> / <sub>8</sub>	3 <sup>1</sup> / <sub>4</sub>	35	5
2 <sup>1</sup> / <sub>2</sub>	8 <sup>1</sup> / <sub>4</sub>	4 <sup>1</sup> / <sub>2</sub>	10 <sup>1</sup> / <sub>4</sub>	7 <sup>7</sup> / <sub>8</sub>	7 <sup>1</sup> / <sub>4</sub>	6 <sup>3</sup> / <sub>8</sub>	3 <sup>1</sup> / <sub>4</sub>	45	6
3	9 <sup>3</sup> / <sub>4</sub>	7 <sup>3</sup> / <sub>4</sub>	12 <sup>1</sup> / <sub>4</sub>	7 <sup>7</sup> / <sub>8</sub>	7 <sup>1</sup> / <sub>4</sub>	7 <sup>1</sup> / <sub>8</sub>	3 <sup>1</sup> / <sub>2</sub>	75	7
4	10 <sup>3</sup> / <sub>4</sub>	9 <sup>1</sup> / <sub>8</sub>	14	1 <sup>1</sup> / <sub>8</sub>	10	9	4 <sup>3</sup> / <sub>4</sub>	95	15
6	10 <sup>1</sup> / <sub>2A</sub>	11 <sup>1</sup> / <sub>8</sub>	18	1 <sup>1</sup> / <sub>4</sub>	12	12 <sup>5</sup> / <sub>8</sub>	5 <sup>1</sup> / <sub>4</sub>	180	21
8	12	13 <sup>3</sup> / <sub>4</sub>	22	1 <sup>3</sup> / <sub>8</sub>	14	15 <sup>1</sup> / <sub>4</sub>	6 <sup>1</sup> / <sub>2</sub>	265	27
10	12 <sup>1</sup> / <sub>2</sub>	15 <sup>3</sup> / <sub>4</sub>	25 <sup>5</sup> / <sub>8</sub>	1 <sup>1</sup> / <sub>2</sub>	18	18 <sup>1</sup> / <sub>4</sub>	6 <sup>3</sup> / <sub>4</sub>	430	33
12	13	18	29 <sup>1</sup> / <sub>8</sub>	1 <sup>1</sup> / <sub>2</sub>	18	20 <sup>1</sup> / <sub>4</sub>	7 <sup>1</sup> / <sub>2</sub>	557	39

SEQ.	QTY.	DESCRIPTION	MATERIAL
1	1	Handwheel	Cast Iron
2	1	Non-Rising Stem	Low Zinc Bronze
3		Bolts/Nuts	Stainless Steel
4	1	O-Ring Plate	Cast Iron
5	1	Cover	Cast Iron
6		Bolts & Nuts	Stainless Steel
7	1	Stem Nut	Bronze
8	2	Gate	Bronze
9	2	Case Ring	Bronze
11	1	Body, SMJ	Cast Iron
12	1	Capscrew-Washer	Steel-Zinc Coated
13	1	Operating Nut	Cast Iron
14	1	Gasket, Stuffbox	Composition
15	2	O-Rings	Rubber
16	1	Low Torque Bearing	Delrin
17	1	Sq. Hd. Pipe Plugstl w/Teflon	
18	1	Gasket, Neck Flange	Composition
19	4	Capscrew	Sil. Bronze
20	2	Strap	Stainless Steel
21	2	Wedge	Bronze
22	2	Hook	Bronze

# 14"-36" MECHANICAL JOINT C571/F-5065 GATE VALVE

KENNEDY VALVE

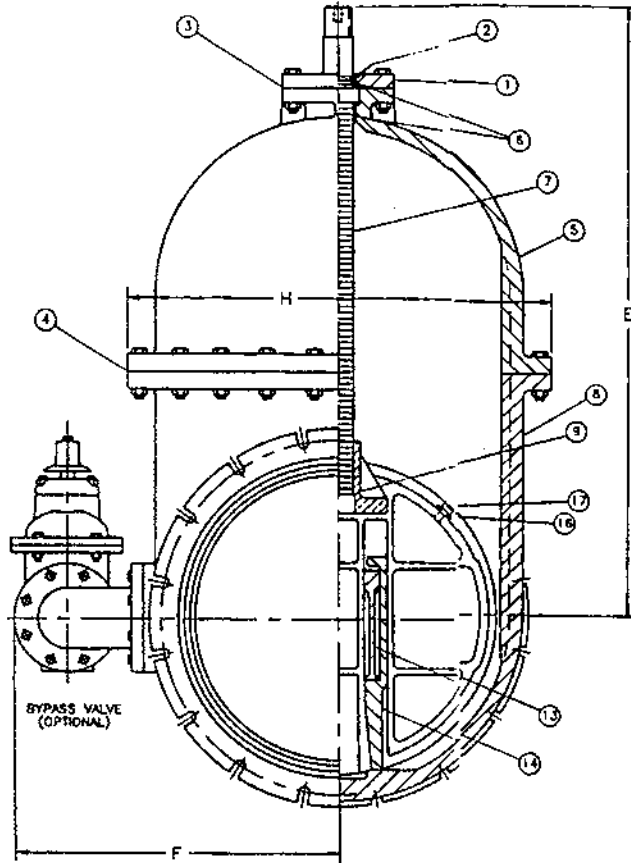
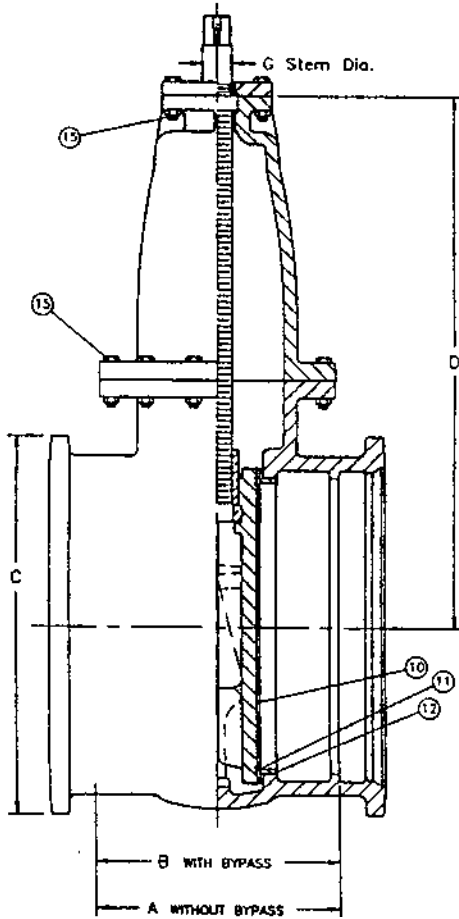

VALVE SIZE	A	B	C	D	E	F	G	H
14	7 <sup>1</sup> / <sub>4</sub>	15 <sup>1</sup> / <sub>2</sub>	20 <sup>1</sup> / <sub>4</sub>	28 <sup>1</sup> / <sub>4</sub>	35 <sup>1</sup> / <sub>4</sub>	19 <sup>1</sup> / <sub>4</sub>	1 <sup>7</sup> / <sub>8</sub>	25 <sup>5</sup> / <sub>8</sub>
16	9 <sup>1</sup> / <sub>8</sub>	13 <sup>3</sup> / <sub>4</sub>	22 <sup>1</sup> / <sub>2</sub>	32 <sup>1</sup> / <sub>4</sub>	39 <sup>1</sup> / <sub>4</sub>	20 <sup>1</sup> / <sub>2</sub>	1 <sup>7</sup> / <sub>8</sub>	25 <sup>3</sup> / <sub>4</sub>
18	9 <sup>1</sup> / <sub>4</sub>	14	24 <sup>3</sup> / <sub>4</sub>	35 <sup>3</sup> / <sub>8</sub>	42 <sup>3</sup> / <sub>8</sub>	22 <sup>1</sup> / <sub>2</sub>	2 <sup>1</sup> / <sub>8</sub>	27 <sup>3</sup> / <sub>4</sub>
20	10	16 <sup>3</sup> / <sub>4</sub>	27	39	46	24	2 <sup>1</sup> / <sub>8</sub>	32 <sup>7</sup> / <sub>8</sub>
24	16	21	32	45 <sup>3</sup> / <sub>8</sub>	52 <sup>3</sup> / <sub>8</sub>	28	2 <sup>1</sup> / <sub>2</sub>	35 <sup>3</sup> / <sub>4</sub>
30	12 <sup>1</sup> / <sub>2</sub>	20 <sup>1</sup> / <sub>4</sub>	39 <sup>1</sup> / <sub>8</sub>	55 <sup>3</sup> / <sub>4</sub>	62 <sup>3</sup> / <sub>4</sub>	31 <sup>1</sup> / <sub>2</sub>	2 <sup>3</sup> / <sub>4</sub>	45 <sup>3</sup> / <sub>4</sub>
36	23 <sup>3</sup> / <sub>4</sub>	23 <sup>3</sup> / <sub>4</sub>	46	65 <sup>1</sup> / <sub>4</sub>	72 <sup>1</sup> / <sub>4</sub>	40	3	56 <sup>1</sup> / <sub>4</sub>

SEQ.	QTY.	DESCRIPTION	MATERIAL
1	1	O-Ring Plate	Cast Iron, ASTM A126 Class B
2	2	O-Ring	Buna N
3	1	Stuffing Box Gasket	Composition
4	1	Neck Flange Gasket	Buna-N
5	1	Cover	Cast Iron, ASTM A126 Class B
6	2	Bushing	Bronze; ASTM B584 Alloy 844
7	1	Stem	Bronze; ASTM B584 Alloy 867
8	1	Body	Cast Iron, ATSM A126 Class B
9	1	Stem Nut	Bronze, ASTM B584 Alloy 844
10	2	Gate	Cast Iron, ASTM A126 Class B
11	2	Gate Ring	Bronze, ASTM B584 Alloy 844
12	2	Case Ring	Bronze, ASTM B584 Alloy 844
13	2	Wedge	Bronze, ASTM B584 Alloy 844
14	2	Hook	Cast Iron, ASTM A126 Class B
15		Bolts & Nuts	Stainless Steel, ASTM F593-304
16	2	Strap	Bronze, ASTM B584 Alloy 844
17	4	Peg	Bronze, ASTM B584 Alloy 844

# 14" - 24" DOUBLE DISC SPUR GEAR MATERIAL LIST

KENNEDY VALVE

C561/F5070

DET	QTY	Description	MATERIAL
1	1	Body	Gray Iron, ASTM A126 Class B
2	1	Cover	Gray Iron, ASTM A126 Class B
3	1	Cap	-----
4	2	Hook	Gray Iron, ASTM A126 Class B
5	2	Wedge	Bronze, ASTM B584 C83600
6	4	Gate Peg	Bronze, ASTM B584 C83600
7	2	Strap	Bronze, ASTM B584 C83600
8	1	Extension	Ductile Iron, ASTM A536 65-45-12
9	1	Actuator 2:1 Actuator 3:1	14"-16" Only 18"-24" Only
10	4	Socket Head Bolt	Alloy Steel
11	1	Stem Nut	Bronze, ASTM B584 C83600
12	3	Oring-Stem	NBR
13	2	Oring-Cover	NBR
14	1	Oring-Extension	NBR
15	4	Capscrew	Stainless Steel, ASTM F593-304
16	1	Stem	Bronze, ASTM B584 C86700
17	8	Nut	Stainless Steel, ASTM F593-304
18	1	Adaptor Plate	Ductile Iron, ASTM A536 65-45-12
19	18	Capscrew	Zinc Chromate
20	1	Gasket-Actuator	Buna-N
21	18	Nut	Stainless Steel, ASTM F593-304
22	1	Pipe Plug	Steel
23	1	Key	Steel
24	1	Oring-Cover Top	NBR
25	1	Op Nut	Ductile Iron, ASTM A536 65-45-12
26	1	Track	Bronze, ASTM B584 C83600
27	1	Bushing	Bronze, ASTM B584 C83600
28	1	Shaft	Bronze, ASTM B584 C83600
29	1	Roller	Bronze, ASTM B584 C83600
30	2	Scraper	Bronze, ASTM B584 C83600
31	1	Bushing	Bronze, ASTM B584 C83600
32	2	Gate	Gray Iron, ASTM A126 Class B
33	2	Gate Ring	Bronze, ASTM B584 C83600
34	2	Case Ring	Bronze, ASTM B584 C83600
35	1	Thrust Washer	Delrin (18"-24")

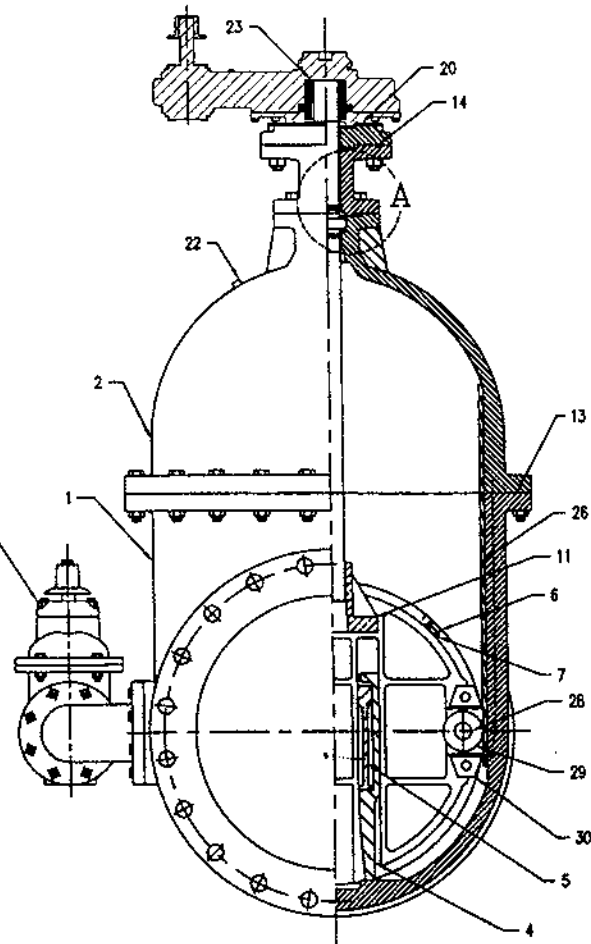
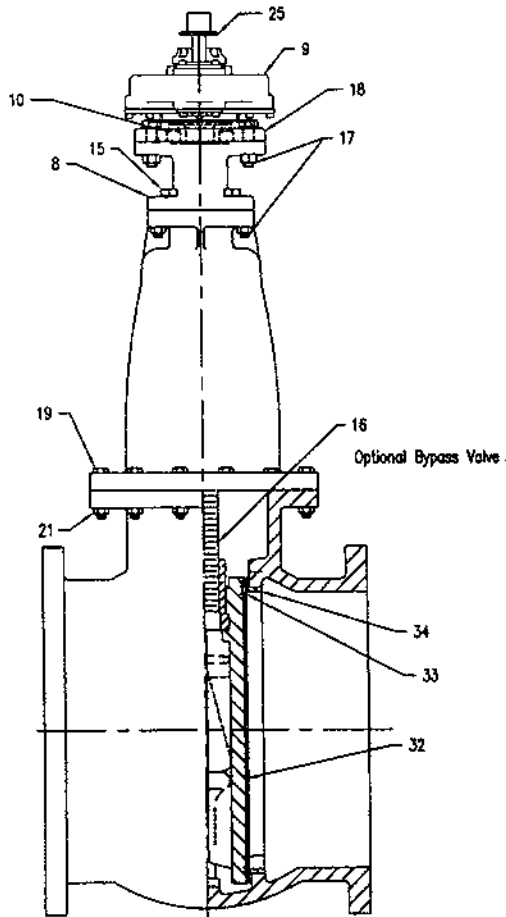
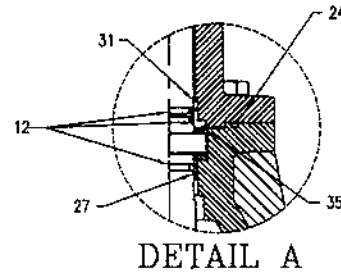

# 14" - 24" DOUBLE DISC SPUR GEAR FLANGE END DIMENSIONAL LIST

KENNEDY VALVE

C561/F5070

VALVE SIZE	14	16	18	20	24
A	15-3/4	17	19	20	23
B	23	23	24	24	28-1/2
C	21	23-1/2	25	27-1/2	32
D	38-3/4	42-3/4	48-7/8	52-1/2	59
E	42-1/2	46-1/2	52-1/2	56	62-1/2
F	19-1/4	20-1/2	22-1/2	24	28
G	1-7/8	1-7/8	2-1/8	2-1/8	2-1/2
H	23-5/8	25-3/4	27-3/4	32-7/8	35-3/4
K	8	8	12	12	12
L	1-3/8	1-7/16	1-9/16	1-11/16	1-7/8
M	7/8	7/8	15/16	1	1-1/8
URNS TO OPEN	90	104	174	192	228

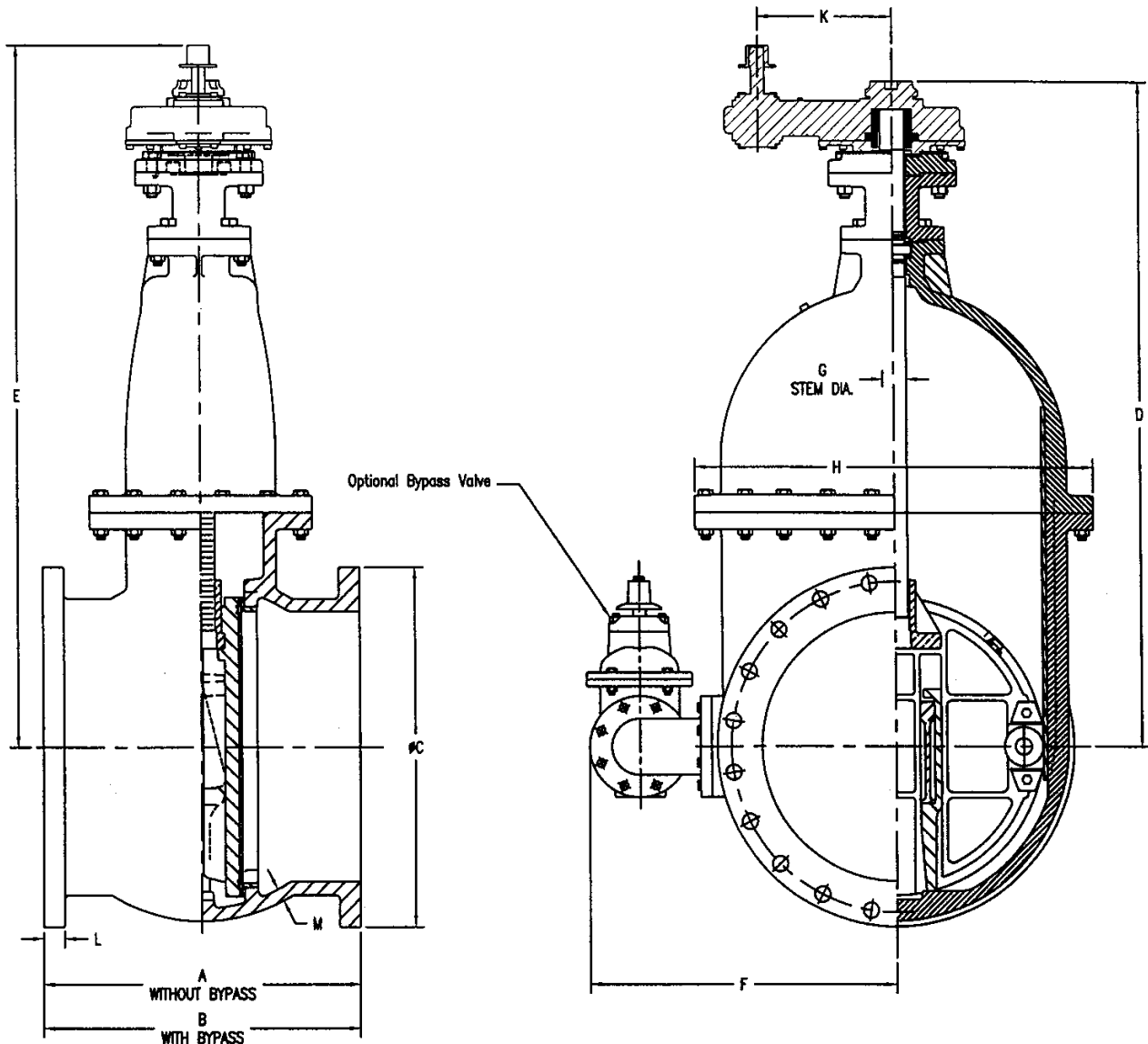

# 14" - 24" DOUBLE DISC SPUR GEAR MJ DIMENSIONAL LIST

KENNEDY VALVE

C571/F5065

VALVE SIZE	14	16	18	20	24
A	7-1/4	9-1/8	9-1/4	10	16
B	15-1/2	13-3/4	14	16-3/4	21
C	20-1/4	22-1/2	24-3/4	27	32
D	38-3/4	42-3/4	48-7/8	52-1/2	59
E	42-1/2	46-1/2	52-1/2	56	62-1/2
F	19-1/4	20-1/2	22-1/2	24	28
G	1-7/8	1-7/8	2-1/8	2-1/8	2-1/2
H	23-5/8	25-3/4	27-3/4	32-7/8	35-3/4
K	8	8	12	12	12
L	1-3/8	1-7/16	1-9/16	1-11/16	1-7/8
M	7/8	7/8	15/16	1	1-1/8
URNS TO OPEN	90	104	174	192	228

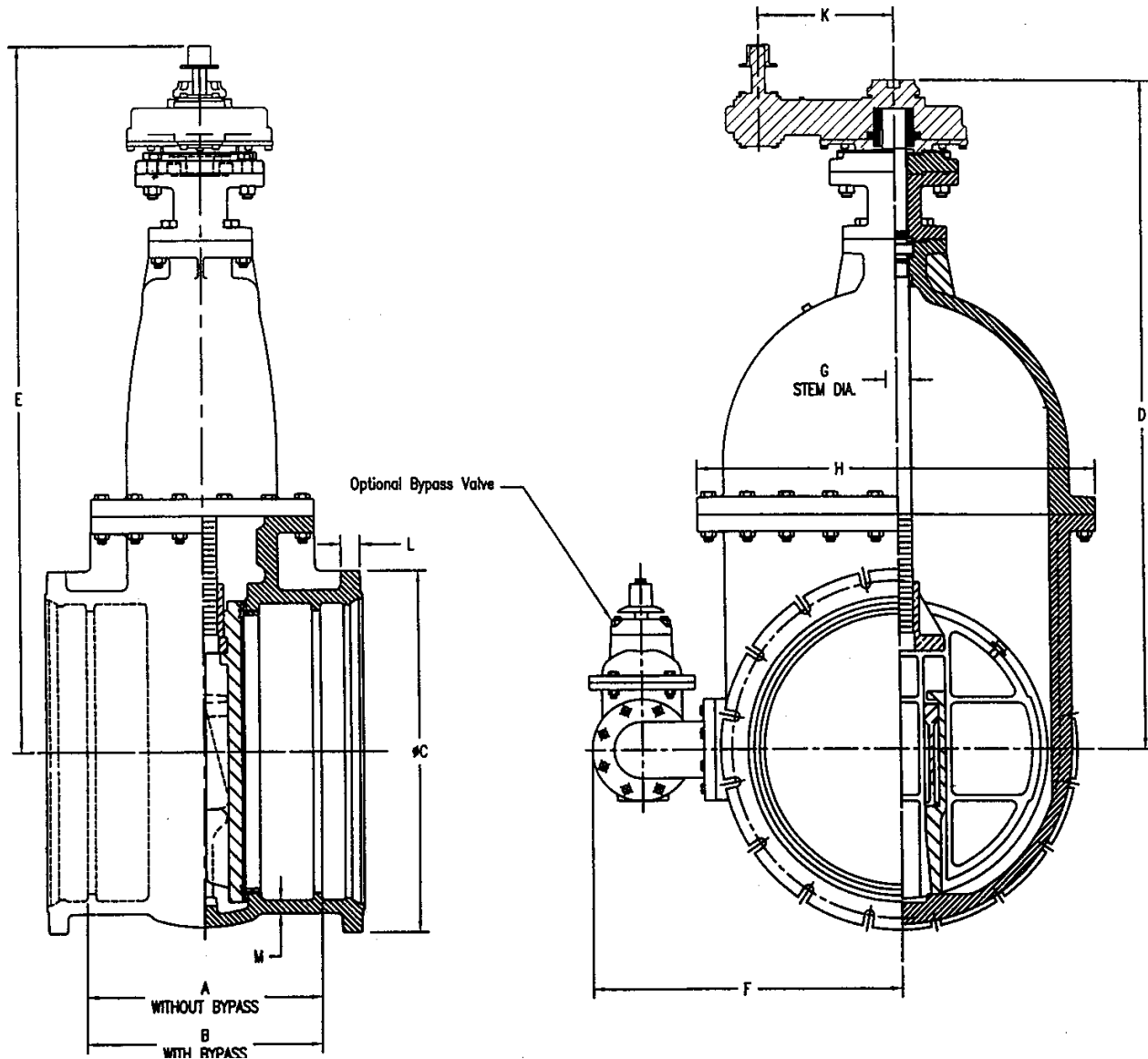

DET	QTY	Description	MATERIAL
1	1	Body	Gray Iron, ASTM A126 Class B
2	1	Cover	Gray Iron, ASTM A126 Class B
3	1	Cap	-----
4	2	Hook	Gray Iron, ASTM A126 Class B
5	2	Wedge	Bronze, ASTM B584 C83600
6	4	Gate Peg	Bronze, ASTM B584 C83600
7	2	Strap	Bronze, ASTM B584 C83600
8	1	Extension	Ductile Iron, ASTM A536 65-45-12
9	1	Actuator 2:1 Actuator 3:1	14"-16" Only 18"-24" Only
10	4	Socket Head Bolt	Alloy Steel
11	1	Stem Nut	Bronze, ASTM B584 C83600
12	3	Oring-Stem	NBR
13	2	Oring-Cover	NBR
14	1	Oring-Extension	NBR
15	4	Capscrew	Stainless Steel, ASTM F593-304
16	1	Stem	Bronze, ASTM B584 C86700
17	8	Nut	Stainless Steel, ASTM F593-304
18	1	Adaptor Plate	Ductile Iron, ASTM A536 65-45-12
19	18	Capscrew	Zinc Chromate --
20	1	Gasket-Actuator	Buna-N
21	18	Nut	Stainless Steel, ASTM F593-304
22	1	Pipe Plug	Steel
23	1	Key	Steel
24	1	Oring-Cover Top	NBR
25	1	Op Nut	Ductile Iron, ASTM A536 65-45-12
26	1	Track	Bronze, ASTM B584 C83600
27	1	Bushing	Bronze, ASTM B584 C83600
28	1	Shaft	Bronze, ASTM B584 C83600
29	1	Roller	Bronze, ASTM B584 C83600
30	2	Scraper	Bronze, ASTM B584 C83600
31	1	Bushing	Bronze, ASTM B584 C83600
32	2	Gate	Gray Iron, ASTM A126 Class B
33	2	Gate Ring	Bronze, ASTM B584 C83600
34	2	Case Ring	Bronze, ASTM B584 C83600
35	1	Thrust Washer	Delrin (18"-24")

## 14" - 24" DOUBLE DISC BEVEL GEAR MATERIAL LIST

KENNEDY VALVE

C561/F5070

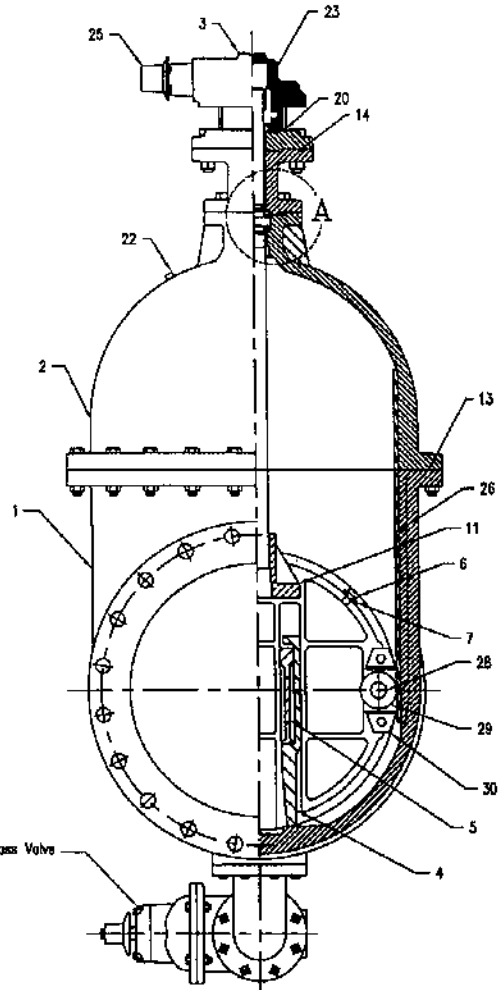
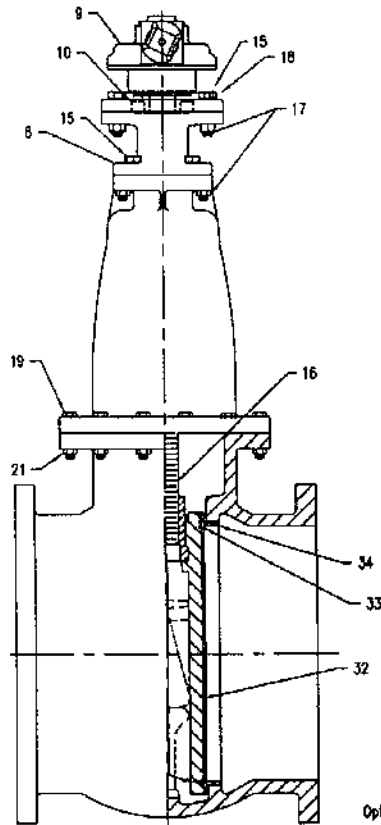
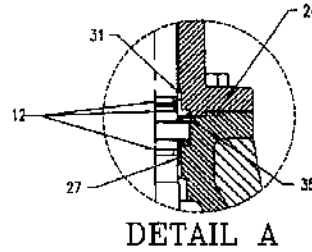

# 14" - 24" DOUBLE DISC BEVEL GEAR FLANGE END DIMENSIONAL LIST

KENNEDY VALVE

C561/F5070

VALVE SIZE	14	16	18	20	24
A	15-3/4	17	19	20	23
B	23	23	24	24	28-1/2
C	21	23-1/2	25	27-1/2	32
D	37	41	47-7/8	51-1/2	58
E	39-1/4	43-1/4	50-3/8	54	60-1/2
F	19-1/4	20-1/2	22-1/2	24	28
G	1-7/8	1-7/8	2-1/8	2-1/8	2-1/2
H	23-5/8	25-3/4	27-3/4	32-7/8	35-3/4
K	9-1/4	9-1/4	10-1/4	10-1/4	10-1/4
L	1-3/8	1-7/16	1-9/16	1-11/16	1-7/8
M	7/8	7/8	15/16	1	1-1/8
URNS TO OPEN	90	104	174	192	228

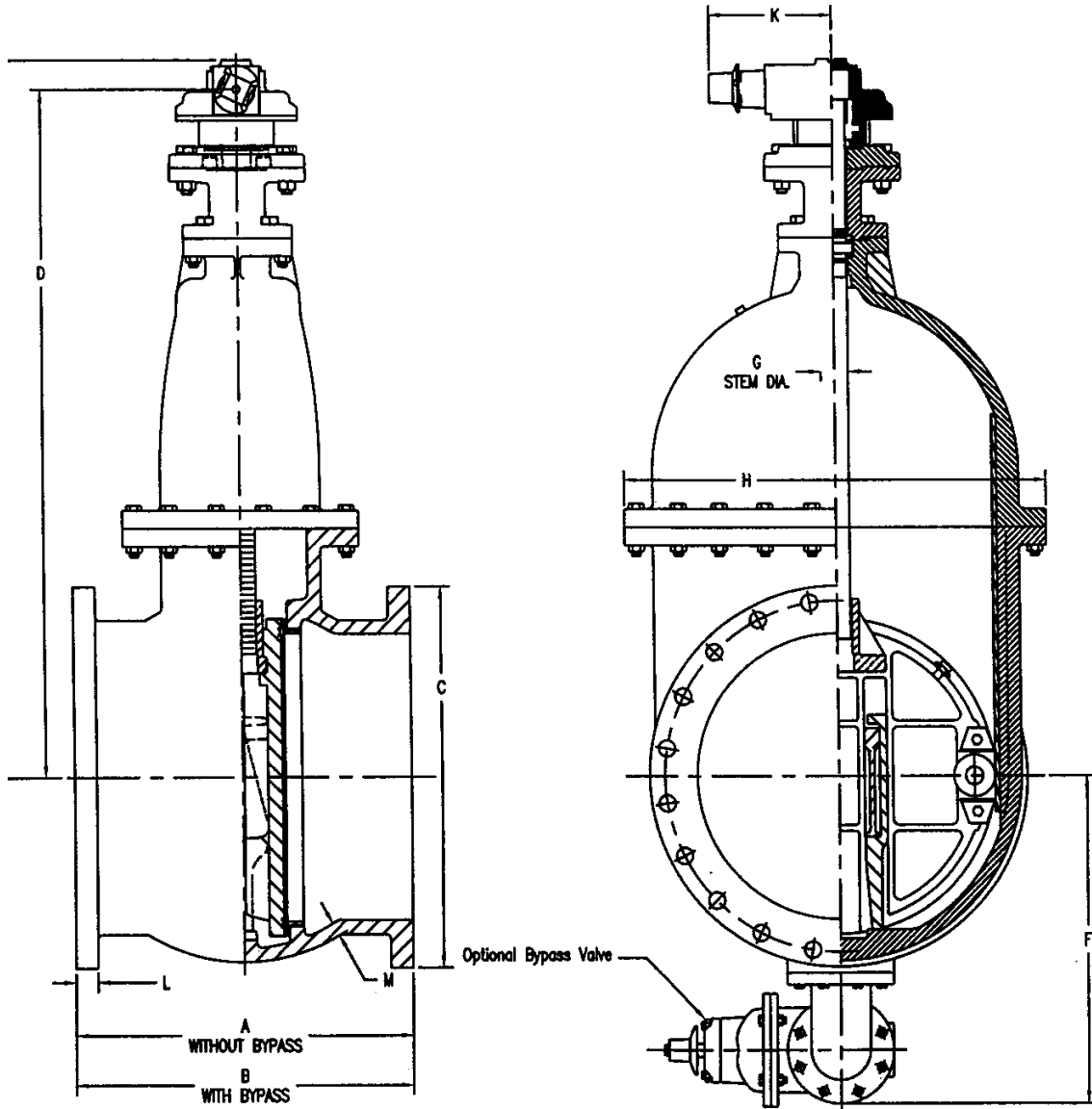

# 14" - 24" DOUBLE DISC BEVEL GEAR FLANGE END DIMENSIONAL LIST

KENNEDY VALVE

C561/F5070

VALVE SIZE	14	16	18	20	24
A	7-1/4	9-1/8	9-1/4	10	16
B	15-1/2	13-3/4	14	16-3/4	21
C	20-1/4	22-1/2	24-3/4	27	32
D	37	41	47-7/8	51-1/2	58
E	39-1/4	43-1/4	50-3/8	54	60-1/2
F	19-1/4	20-1/2	22-1/2	24	28
G	1-7/8	1-7/8	2-1/8	2-1/8	2-1/2
H	23-5/8	25-3/4	27-3/4	32-7/8	35-3/4
K	9-1/4	9-1/4	10-1/4	10-1/4	10-1/4
L	1-15/16	1-7/16	1-7/16	1-1/2	1-5/8
M	7/8	7/8	15/16	1	1-1/8
TURNS TO OPEN	90	104	174	192	228

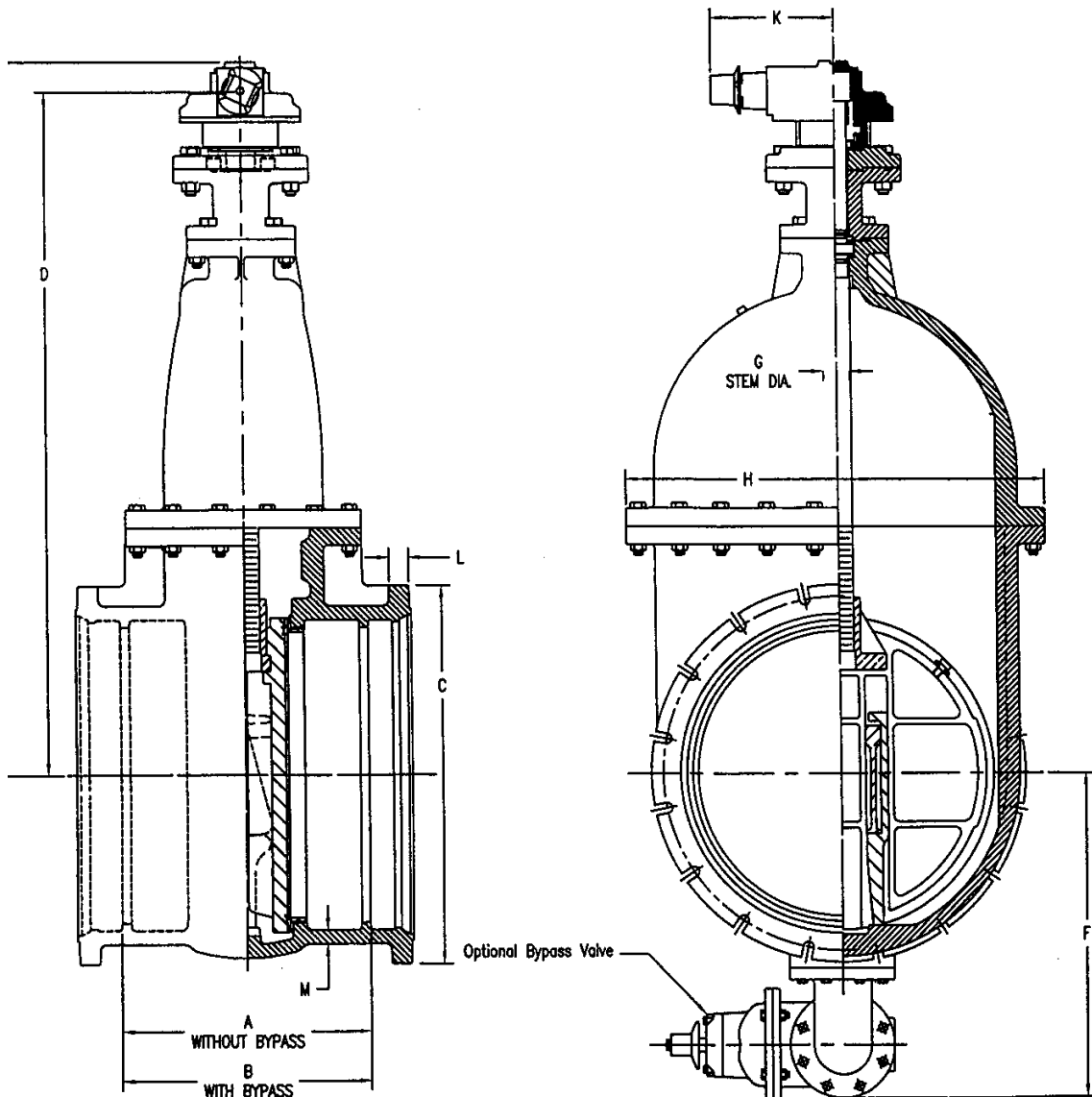

**For 14-inch and Larger Diameter Gate Valves  
Installed Horizontally**

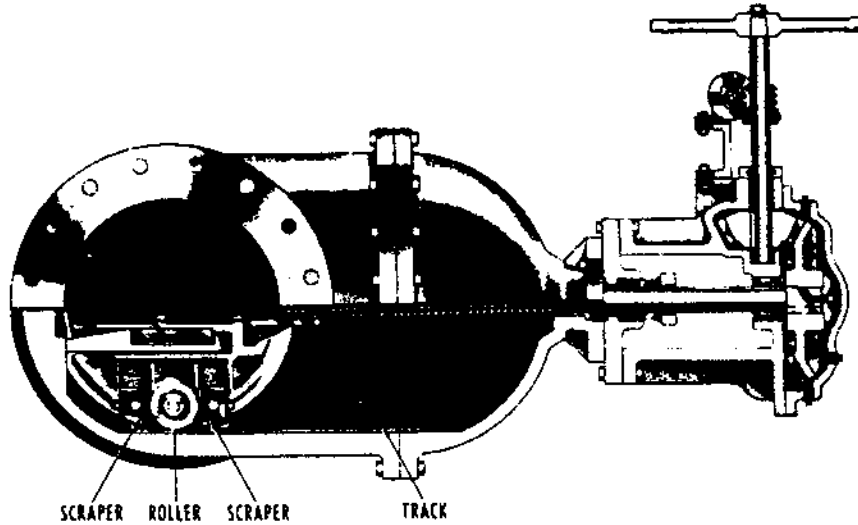

Cutaway view of valve showing rollers, tracks, and scrapers

**Rollers, Tracks and Scrapers**

Valves 14" and larger installed in a horizontal pipe line with their stems horizontal should be equipped with rollers, tracks and scrapers, as illustrated. The rollers assist the travel of the gate assembly along tracks set into the valve body, retaining it in alignment, and promoting ease of operation, not otherwise possible. Scrapers are provided ahead of the rollers to clear the track of obstruction or foreign matter. When required, rollers, tracks and scrapers are bronze.

Valve installed horizontally in a horizontal pipe line

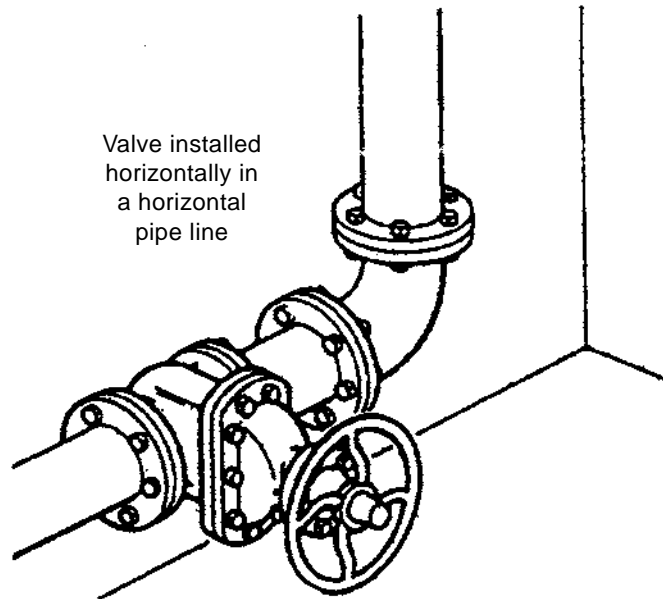

**KENNEDY LIST 16 EXTRA HEAVY  
PRESSURE DBL. DISC, PARALLEL  
SEAT IBBM GATE VALVES**

KENNEDY VALVE

**KENNEDY VALVE LIST 16 Dbl. Discs Parallel Seat  
IBBM Gate Valves Meet or Exceed  
the requirements of AWWA C500**

<b>Size Range</b>	<b>4"-30"</b>
-------------------	---------------

	Water Working Pressure psi	Hydrostatic Test psi
4"-20"	250	500
24"-30"	225	450

Available in either, NRS or OS&Y.

**Available End Connections & Size Range      Figure No.**

Fig. (NRS) 4" - 48"

F-5300

Fig. (OS&Y) 14" - 48"

F-5305

**Accessories**

Same as listed for Kennedy Valve AWWA Dbl. Disc  
Parallel Seat IBBM Gate Valves

Flanges are faced and drilled to ANSI Class 250 Standard

# LIST 16 EXTRA HEAVY DOUBLE DISC GATE VALVES GENERAL DIMENSIONS

## KENNEDY VALVE

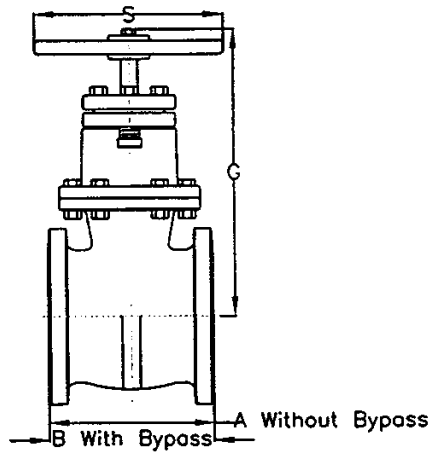

Flanged Ends, NRS

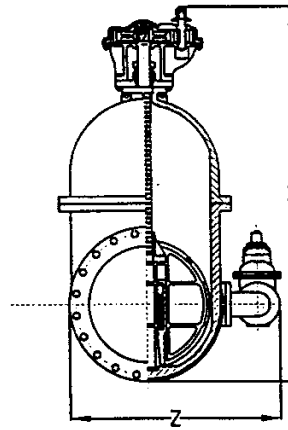

Flanged ends  
NRS Spur  
Gear  
By-Pass

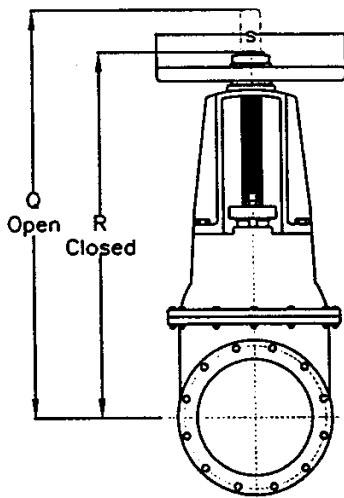

Flanged Ends, OS&Y

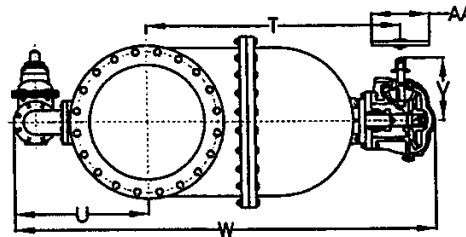

Flanged ends, NRS,  
with Bevel Gears,  
By-Pass

VALVE SIZE	A	B	G	Q	R	S	T	U	V	W	X	Y	Z	AA	Turns to Open	Diam. of Stem
4	9 <sup>5</sup> / <sub>8</sub>	—	14	24	19 <sup>3</sup> / <sub>4</sub>	10	—	—	—	—	—	—	—	—	15	1 <sup>1</sup> / <sub>8</sub>
6	11 <sup>1</sup> / <sub>2</sub>	—	18	32 <sup>1</sup> / <sub>2</sub>	25 <sup>1</sup> / <sub>2</sub>	12	—	—	—	—	—	—	—	—	21	1 <sup>1</sup> / <sub>4</sub>
8	12 <sup>1</sup> / <sub>2</sub>	—	22	40 <sup>1</sup> / <sub>2</sub>	31 <sup>1</sup> / <sub>2</sub>	14	—	—	—	—	—	—	—	—	27	1 <sup>3</sup> / <sub>8</sub>
10	14 <sup>1</sup> / <sub>2</sub>	—	25 <sup>5</sup> / <sub>8</sub>	47 <sup>1</sup> / <sub>4</sub>	36 <sup>1</sup> / <sub>4</sub>	18	—	—	—	—	—	—	—	—	33	1 <sup>1</sup> / <sub>2</sub>
12	17	—	29 <sup>1</sup> / <sub>8</sub>	58 <sup>1</sup> / <sub>4</sub>	45 <sup>3</sup> / <sub>4</sub>	18	27 <sup>5</sup> / <sub>8</sub>	—	13	—	36 <sup>1</sup> / <sub>8</sub>	8	—	18	39	1 <sup>1</sup> / <sub>2</sub>
14	17 <sup>1</sup> / <sub>2</sub>	26 <sup>1</sup> / <sub>4</sub>	36 <sup>1</sup> / <sub>4</sub>	67 <sup>3</sup> / <sub>4</sub>	52 <sup>3</sup> / <sub>4</sub>	22	33	21	13	58 <sup>1</sup> / <sub>4</sub>	41	8	33	18	45	1 <sup>7</sup> / <sub>8</sub>
16	19	27 <sup>1</sup> / <sub>2</sub>	40 <sup>1</sup> / <sub>4</sub>	74 <sup>3</sup> / <sub>4</sub>	57 <sup>3</sup> / <sub>4</sub>	26	36 <sup>7</sup> / <sub>8</sub>	22	13	64	45	8	35 <sup>1</sup> / <sub>4</sub>	18	52	2
18	21	27 <sup>1</sup> / <sub>2</sub>	43 <sup>3</sup> / <sub>8</sub>	82 <sup>1</sup> / <sub>2</sub>	63 <sup>1</sup> / <sub>2</sub>	26	39 <sup>7</sup> / <sub>8</sub>	24	13	69 <sup>3</sup> / <sub>4</sub>	48	8	38 <sup>1</sup> / <sub>2</sub>	18	58	2 <sup>1</sup> / <sub>8</sub>
20	21 <sup>1</sup> / <sub>2</sub>	28	48	90 <sup>1</sup> / <sub>4</sub>	69 <sup>1</sup> / <sub>4</sub>	30	43 <sup>3</sup> / <sub>4</sub>	24 <sup>3</sup> / <sub>4</sub>	13	74	51 <sup>3</sup> / <sub>4</sub>	8	41 <sup>1</sup> / <sub>2</sub>	18	64	2 <sup>1</sup> / <sub>4</sub>
24	26	34	54 <sup>3</sup> / <sub>8</sub>	105	79 <sup>3</sup> / <sub>4</sub>	30	52 <sup>7</sup> / <sub>8</sub>	29 <sup>1</sup> / <sub>2</sub>	17 <sup>1</sup> / <sub>2</sub>	89	60 <sup>5</sup> / <sub>8</sub>	10	47 <sup>1</sup> / <sub>4</sub>	18	51	2 <sup>1</sup> / <sub>4</sub>
30	30	34	65 <sup>3</sup> / <sub>8</sub>	128 <sup>1</sup> / <sub>4</sub>	97	36	64 <sup>1</sup> / <sub>8</sub>	33 <sup>1</sup> / <sub>2</sub>	23 <sup>3</sup> / <sub>4</sub>	105 <sup>1</sup> / <sub>2</sub>	79 <sup>1</sup> / <sub>8</sub>	13 <sup>3</sup> / <sub>8</sub>	57 <sup>1</sup> / <sub>2</sub>	22	63	3

FLANGES ARE FACED AND DRILLED TO ANSI CLASS 250 STANDARD

Note: 36", 42", and 48" Dimensions Contact Factory

# KENNEDY VALVE AWWA DOUBLE DISC GATE VALVES IRON BODY, BRONZE MOUNTED, PARALLEL SEAT

KENNEDY VALVE

## Description and Advantages

Kennedy Valve AWWA Gate Valves are designed primarily for flow control of water in underground pipe lines. They equal or exceed the requirements established by standards of the American Water Works Association and conform to Federal Specifications WW-V-58B, Type II, Class I.

Kennedy Valve AWWA Gate Valves are specifically designed for heavy pressure service. Neck, flanges, and bell are made extra heavy to withstand pipe strain and possible shifting. Body, cover, gates, and stem are built for extra strength, with clean and simple internal construction, to assure long service and low maintenance.

## Operation of the Valve

Turning the stem releases the wedging pressure on the gates allowing them to move away from their seats before starting upward travel. Further turning of the stem raises the gates into the fully opened position.

When closing the valve, the gates move freely downward without friction, to a position opposite their seats.

As the gates approach the bottom of the valve, the iron hooks come into contact with stops which prevent further downward movement of the hooks. The bronze wedges riding on these hooks spread the gates apart and force them against their seats.

## Construction

**Body:** Cast iron, bronze mounted. Sturdy proportions provide protection against damage.

**Stem:** Manganese bronze of high tensile and torsional strength, with accurate, perfectly machined threads. Ample diameters assure smooth valve movements.

**Stem Nut:** Solid bronze. Independent of hooks, gates, and wedges. Stem or stem nut will not bind or spring out of line, as can happen when stem nut is attached to wedges.

**Wedges:** Independent, solid bronze, 2"-3" valves have integral hook and wedge. 4"-8" have independent solid bronze wedges placed loosely in iron hooks, and are free

to adjust to varying positions of the gates. In 10" and larger valves, each wedge has one long and one short surface. The bottom of each wedge forms a rocker bearing on the iron hooks, letting wedges adjust to varying positions of the gates in closing. The long side is used in closing the valve and the short side in opening it.

**Low Torque Trust Bearing:** Valves 4"-12" are fitted below the stem collar with an exclusive Low Torque Thrust Bearing which provides high load capacity and low friction. This bearing reduces operating torque up to 50% yet seals perfectly for repacking under pressure.

**Gates and Gate Rings:** Gates 3" and smaller are bronze. Gates 4" and larger are high strength cast iron with bronze gate rings rolled into machined and dovetailed grooves under pressure to make gate and ring one inseparable unit. After fitting, gate rings are accurately machined.

**Case Rings.** Bronze case rings are screwed into place and machined. They can be removed and replaced if necessary.

**Packing:** O-Ring packing is standard on all non-rising stem gate valves. Rising stem and geared valves are furnished with conventional packing.

**Operating Nut and Handwheel:** All valves except flanged valves and outside screw and yoke valves are supplied with 2" square operating nuts of high strength cast iron unless otherwise specified. Flanged valves and outside screw and yoke valves are supplied with handwheels of high strength cast iron unless otherwise specified. Direction of opening is indicated by arrow cast on operating nut skirt or on the rim of the handwheel.

**Yoke:** Yokes for outside screw and yoke valves are of rugged cast iron. Careful machining assures accurate stem alignment.

**Accessories:** Valves may be fitted with any large number of accessories: cylinders, electric motor operators, gearing, by-passes, etc.

**Rollers, Tracks and Scrapers:** Recommended for 14" and larger diameter valves carry weight of the gates for valves installed in a horizontal line in a vertical line.

**NOTE:** All valves open to the left (counter clockwise) unless otherwise specified.

**SAMPLE GATE VALVE SPECIFICATION  
KENNEDY VALVE CAST IRON GATE VALVE**

KENNEDY VALVE

**Gate Valves:**

Valves shall be manufactured in accordance with AWWA Standard C500-93. Valves 12" and smaller shall be designed for 200 psi water working pressure and 150 psi for valves 14"-48" inclusive. Valves shall have (M/J, Flanged or as indicated on plans) ends and shall have clear waterway equal to the full nominal diameter of the valve. Valves shall be double disc parallel seat type with (non-rising, rising) stems, opening by turning (left, right) and provided with (2" square nuts, handwheel), with arrow cast in metal to indicate direction of opening.

Manufacturer of 2"-48" gate valves must have the full range of valves in both NRS and OS&Y styles.

Each manufacturer shall provide certification that they have manufactured 2" through 48" valves for a minimum of ten years.

Each valve shall have manufacturer's name, pressure rating and year in which manufactured cast on body. Prior to shipment from the factory each valve shall be hydrostatically shell tested at a pressure of 400 psig in sizes 12" and smaller and 300 psig in sizes 14" and larger. In addition each valve shall be hydrostatically seat tested at a pressure of 200 psig in sizes 12" and smaller and 150 psig in sizes 14" and larger. Valves shall be Kennedy Valve AWWA valves as furnished by Kennedy Valve, Elmira, New York.

**Stuffing Boxes:**

Stuffing Boxes shall be "O" ring seal type with two O-rings located in stem above thrust collar in valves without gearing. Sizes 14" through 48" there shall be a bronze busing meeting ASTM B584.

Bolts and Nuts:

Body and cover bolts and nuts shall meet specification ASTM F593-304 Stainless Steel.

**Wedging:**

Valves will be bottom wedging type with two part floating wedge contact. The wedge and hook shall be separate coatings and not a one piece casting in valves 4" through 36". In valves 42" and 48" the hooks and wedges shall be one piece design with the outside of the wedge area covered with a bronze shoe. No side wedging will be acceptable.

**Stems:**

Stems shall be in full conformance with AWWA Specs. Sizes 14" through 36" bronze ASTM B584 with 80,000 tensile strength, and cast integral stem collar. 42" and 48" shall be type 304 stainless steel.

**Stem Nuts:**

Stem nuts shall be made of solid bronze independent of hooks, gates and wedges. No pins will be allowed to retain gates to stem nuts.

**Gates and Gate Rings:**

Gates shall be high strength cast iron, sturdily proportioned without pockets on backs. Cam surfaces shall open to bottom. Gate rings shall be rolled into dovetailed grooves under pressure to make one inseparable unit. The gate ring face shall be machined to a smooth finish.

**Case Rings:**

Bronze case rings shall be screwed into place and the contact face machined to a smooth finish. Use of screws, rivets or other means of retention will not be acceptable.

Valves 14" and Larger:

Valves installed with stem horizontal shall be equipped with bronze rollers, tracks, scrapers.

**Bypasses:**

Bypasses shall be provided on 16" and larger valves where indicated and mounted directly to valve body with cast iron flanged connections. Bypass valves shall be resilient seated AWWA and ULFM approved as furnished by Kennedy Valve for sizes through 36" and integral double disc type bypass valves for 42" and 48" sizes.

**Gearing:**

Enclosed spur or bevel gearing with extended type gear cases will be provided where indicated on plans. Side cover plates will be provided to completely enclose stem and stuffing box. Manufacturer must be able to supply open and enclosed gearing as standard.

## KENNEDY VALVES ORDERING INFORMATION

KENNEDY VALVE

### **Use Figure Number wherever possible to identify product wanted.**

When placing orders or making inquiries, please furnish the following information. This information will enable us to answer your questions, prepare quotations, and fill your order promptly. Lack of essential information is almost sure to cause delays.

1. **Quantity**
2. **Size**
3. **Working pressure:** Refer to tables of pressure ratings.
4. **End type or types:** Gate valves are furnished with many end types.
- 4A. **Flanged valves:** Furnished with ANSI 125 pound Standard flanges with bolt holes straddling center lines.
- 4B. **Mechanical Joint valves:** Normally furnished with standardized mechanical joints with plain rubber gaskets. Cutting-in type mechanical joints also available for use in existing cast iron pipe lines.
5. **Direction of opening:** Must be specified. Open left (counterclockwise); or open right (clockwise).
6. **Type of stem:** State whether non-rising stem or rising stem with outside screw and yoke.
7. **Installation position:** Indicate position in which valve will be installed (vertically, horizontally, or otherwise).
8. **Operating nut or handwheel:** All flanged valves and all rising stem valves with outside screw and yoke are furnished with handwheels unless otherwise specified. Other valves are furnished with a 2-inch square operating nut unless otherwise specified.
9. **Stuffing box:** Whether conventional or O-ring. Unless otherwise specified, we regularly furnish NRS valves with O-ring packing; other valves are regularly furnished with conventional stuffing box packing.
10. **Indicator posts and valves:** State depth of trench (distance from ground line to bottom of the pipe line); size and shape of operating nut, if other than standard. For valves already in place, state whether valve is equipped with a flange for post support; if so, give flange dimensions, and distance from centerline of valve to top of flange.
11. **By-pass Valves:** State location, whether manually operated by-pass will have handwheel or operating nut, and any special instructions necessary.
12. **Parts:** Always order parts by number.