

ECCENTRIC PLUG VALVES

KENNEDY VALVE

Size Range	3"-24"	
	Water Working	Hydrostatic
Size Range	Pressure psi	Test psi
3"-12"	175	350
14"-24"	150	300

Available End Connections & Size Range

Figure No.

Flanged	3"-24"	F-5412
M.J.	3"-24"	F-5413
Grooved	3"-16"	F-5414
Flanged-Full Port	3"-12"	2725

Accessories

Floorstands	Electric Motor Actuators
Extension Stems	Cylinder Actuators
Extended Bonnets	Limit Switches
2" Sq. Operating Nuts	Stem Guides
Handwheels	Floor Boxes
Lever Wrench Head (3"-8")	"T" Handles
Chainwheels	Chainlevers (3"-8")
Worm Gear Actuators	

*Note: Call Factory For Special Applications

Valves 3" through 8" are available with lever actuators. Geared actuators are recommended on 6" and larger valves. It is also recommended that valves installed in pipelines with high velocity or where water hammer conditions can be caused by sudden valve shut-off that geared actuators be installed. Lever actuators can only be used for pressure ratings of 100 psi maximum and 25 psi in the reverse flow condition.

3"-12" ECCENTRIC PLUG VALVE PARTS LIST

KENNEDY VALVE

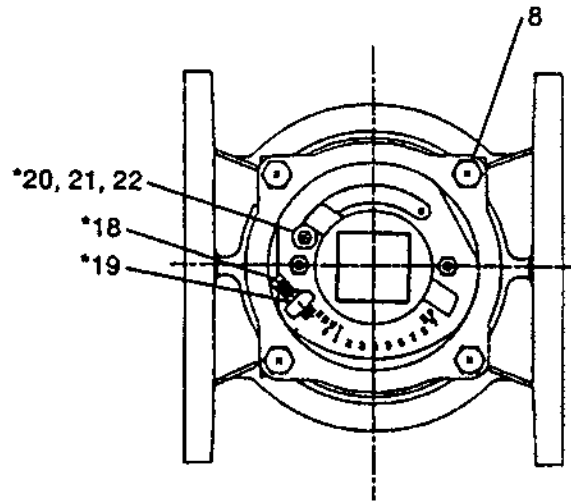
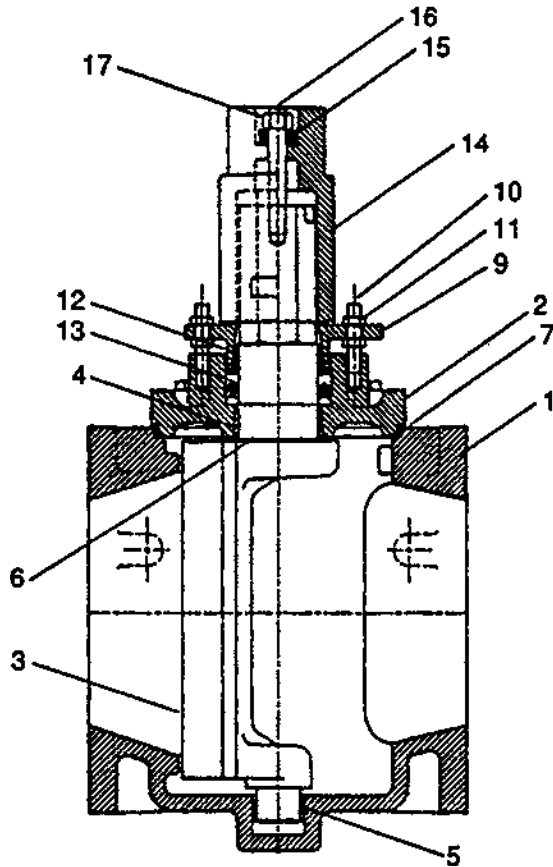

DET.	QTY.	DESCRIPTION	MATERIAL
1	1	Body	Cast Iron ASTM A-126 Class B
2	1	Cover	Cast Iron ASTM A-126 Class B
3	1	Plug	Cast Iron & Buna-N
4	1	Top Bearing	316 Stainless Steel
5	1	Bottom Bearing	316 Stainless Steel
6	1	Thrust Washer	Nylatron
7	1	Cover O-Ring	Buna-N
8		Cover Capscrews	Zinc Plated Steel
9	1	Gland/Brake Follower	Cast Iron ASTM A-126 Class B
10	2	Follower Stud	Zinc Plated Steel
11	4	Follower Nuts	Zinc Plated Steel
12	1	Brake	Glass Reinforced PPS
13	1-Set	Vee Packing	Buna-N
14	1	Operating Nut	Cast Iron ASTM A-126 Class B
15	5	Bellveu Spring Washer	Zinc Plated Steel
16	1	Adjusting Stud	Zinc Plated Steel
17	1	Lock Nut	Zinc Plated Steel
18	1	Square Head Set Screw	Zinc Plated Steel
19	1	Jam Nut	Zinc Plated Steel
20	1	Socket Head Capscrew	Zinc Plated Steel
21	1	Flat Washer	Zinc Plated Steel
22	1	Jam Nut	Zinc Plated Steel

14"-24" ECCENTRIC PLUG VALVE PARTS LIST

KENNEDY VALVE

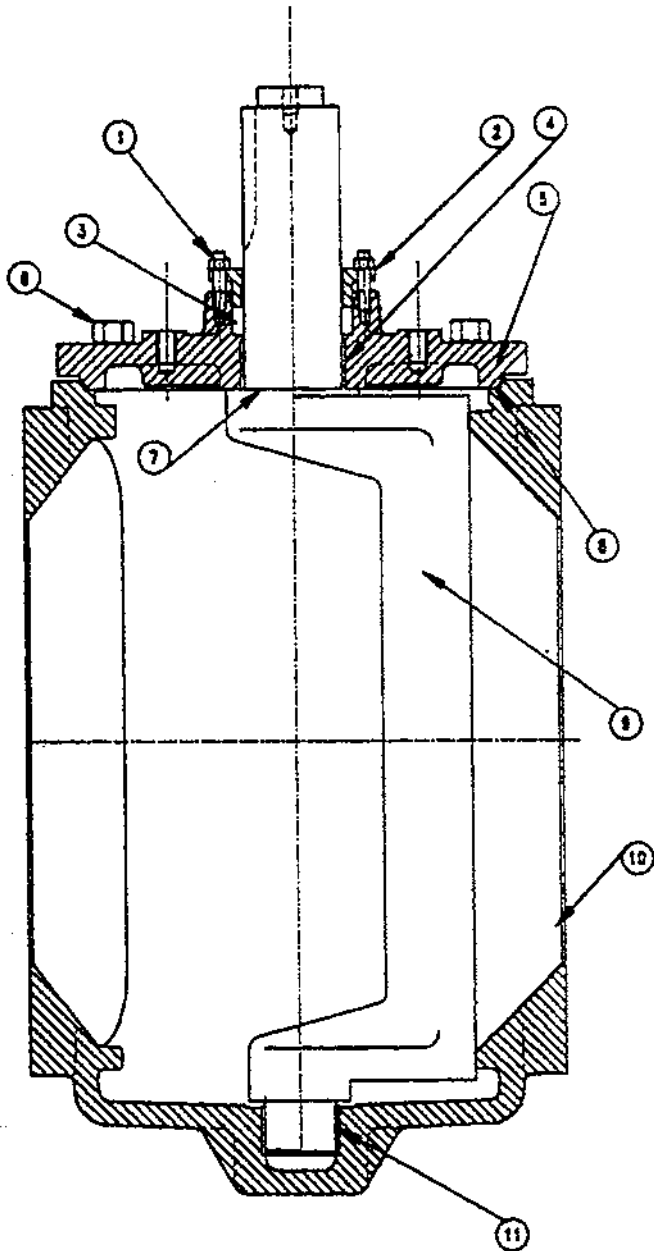

ITEM NO.	DESCRIPTION		ASTM
1	Stud & Hex Nuts	Steel – Zinc Plated	
2	Follower Gland	Cast Iron	ASTM A-126 Class B
3	"V" Ring Seals	Buna-N	
4	316 S S Oil Impregnated Sleeve Bearing		
5	Cover	Cast Iron	ASTM A-126 Class B
6	Hex Head Capscrew	Steel – Zinc Plated	
7	Thrust Washer	Nylatron	
8	Cover O-Ring	Buna-N	
9	Plug	Cast Iron & Buna-N	ASTM A-126 Class B
10	Body	Cast Iron	ASTM A-126 Class B
11	316 S S Oil Impregnated Sleeve Bearing		

3"-24" ECCENTRIC PLUG VALVE WORM GEAR OPERATOR – PARTS LIST

KENNEDY VALVE

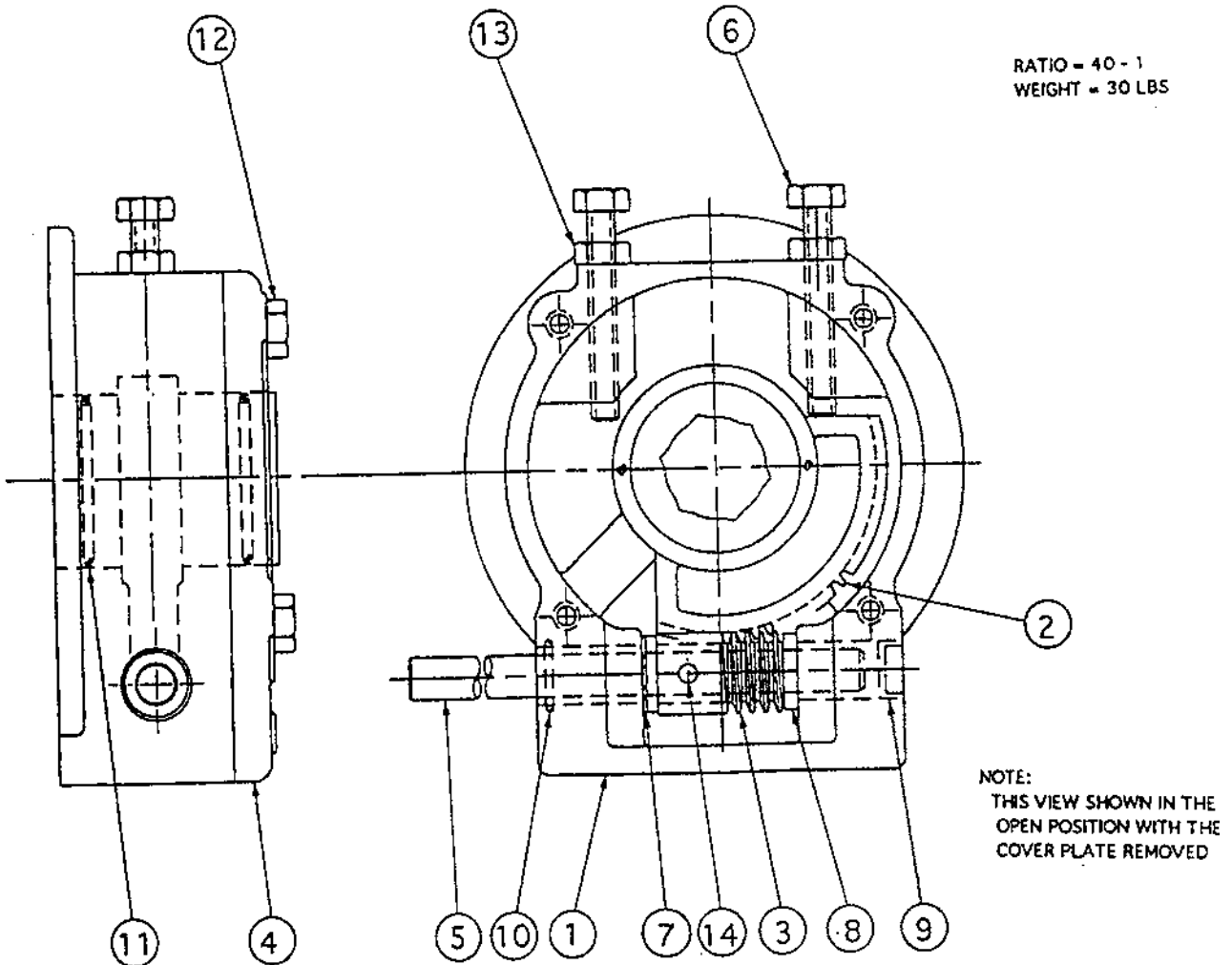

DET.	QTY.	DESCRIPTION	MATERIAL
1	1	Housing	Cast Iron ASTM A-126 Class B
2	1	Drive Sleeve	Manganese Bronze
3	1	Worm	AISI-11L41
4	1	Cover Plate	Cast Iron ASTM A-126 Class B
5	1	Worm Shaft	AISI-11L41
6	2	Stop Screw	ASTM A108
7	2	Shim	Mild Steel
8	2	Thrust Bearing	Oil Impregnated Bronze
9	1	Expansion Plug	ASTM A108
10	2	O-Ring	Buna-N
11	2	O-Ring	Buna-N
12	4	Hex Head Cap Screw	ASTM A100
13	2	Lock Nut	ASTM A-108
14	1	Spring Pin	High Tensile Steel

**3"-8" ECCENTRIC PLUG VALVE
FLANGED ENDS – GENERAL DIMENSIONS**

KENNEDY VALVE

F-5412

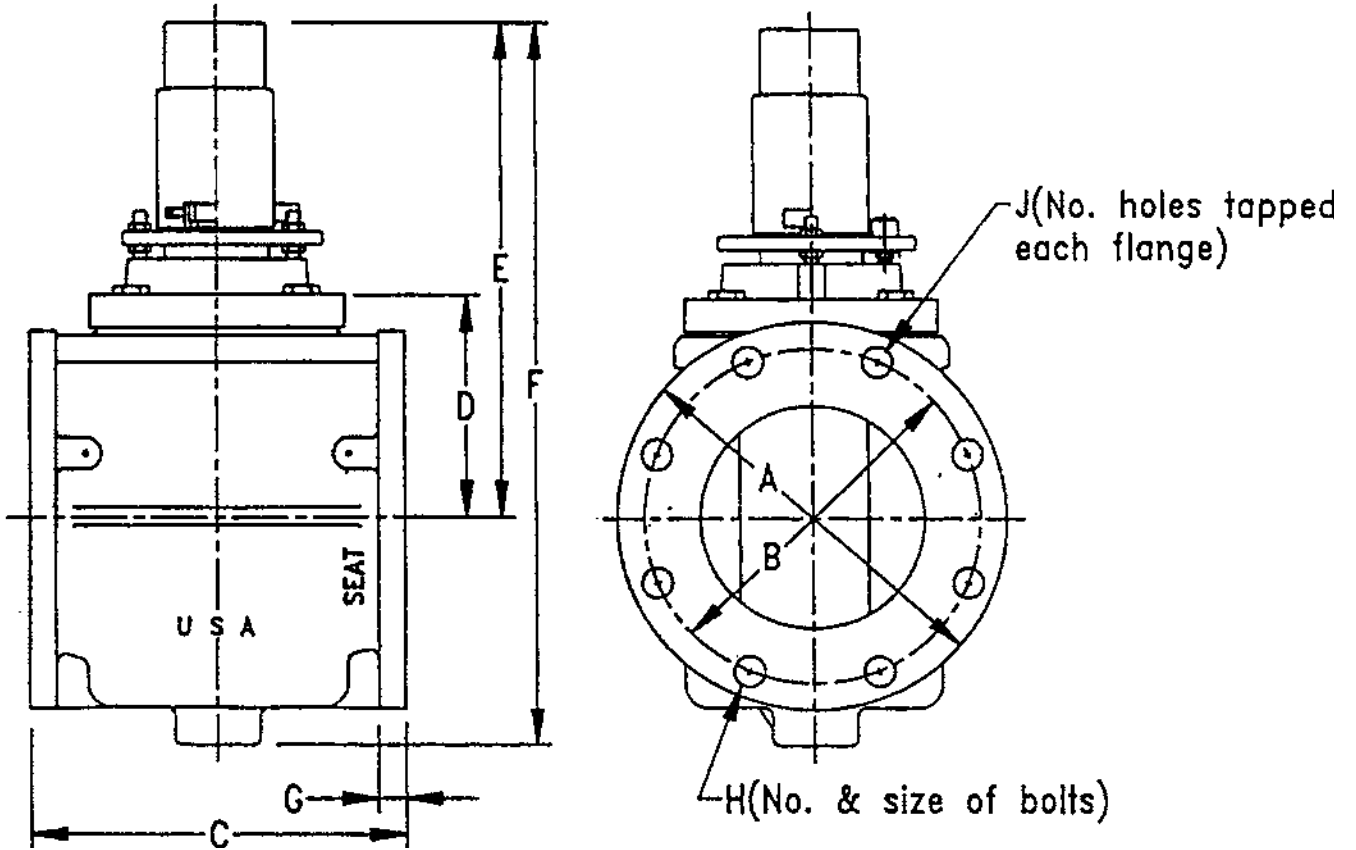

VALVE SIZE	A	B	C	D	E	F	G	H	J
3"	7 ¹ / ₂	6	8	3 ¹⁵ / ₃₂	6 ³ / ₄	11	³ / ₄	4— ⁵ / ₈	0
4"	9	7 ¹ / ₂	9	4 ⁷ / ₁₆	11	16 ³ / ₈	1	8— ⁵ / ₈	4
6"	11	9	10 ¹ / ₂	6 ¹ / ₈	14 ¹ / ₂	21	1 ¹ / ₁₆	8— ³ / ₄	2
8"	13 ¹ / ₂	11 ³ / ₄	11 ¹ / ₂	7 ⁵ / ₈	16	24 ¹ / ₄	1 ¹ / ₁₆	8— ³ / ₄	4

14"-24" ECCENTRIC PLUG VALVE FLANGED ENDS – GENERAL DIMENSIONS

KENNEDY VALVE

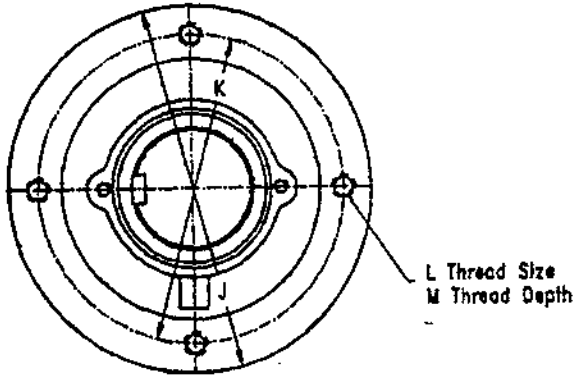

Actuator Mounting Dimensions

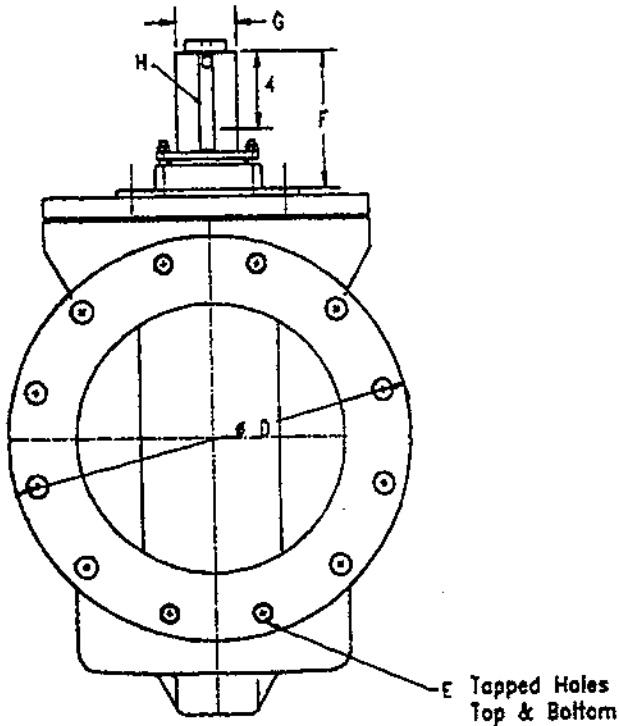
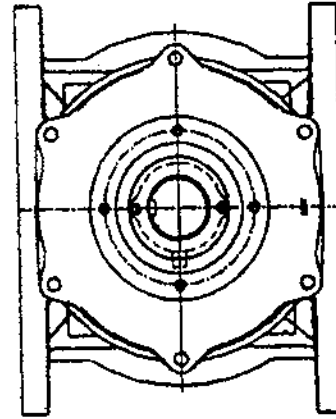

End Flange Dimension
Conform to Ansl B16.1

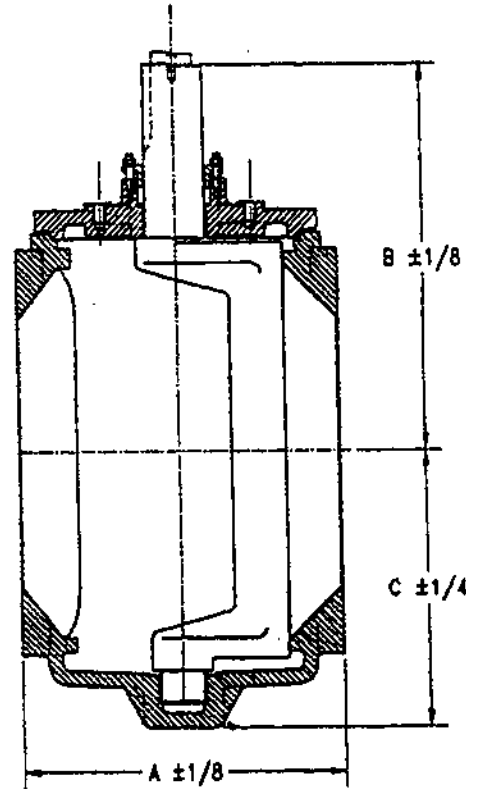

VALVE SIZE	A	B	C	D	E	F	G	H	J	K	L	M
14	17.00	19.69	14.31	21.00	4	6.81	3.121	.75 sq	9.50	8.00	5/8—11	7/8
16	17.75	20.88	15.75	23.50	6	6.81	3.121	.75 sq	9.50	8.00	5/8—11	7/8
18	21.50	22.94	17.18	25.00	8	6.81	3.121	.75 sq	9.50	8.00	5/8—11	7/8
20	23.50	24.22	20.00	27.50	8	6.81	3.121	.75 sq	9.50	8.00	5/8—11	7/8
24	30.00	25.28	22.94	32.00	8	6.81	3.750	.875 sq	11.00	9.00	3/4—10	7/8

**4"-24" ECCENTRIC PLUG VALVE
FLANGED ENDS WITH WORM GEAR –
GENERAL DIMENSIONS**

KENNEDY VALVE

F-5412

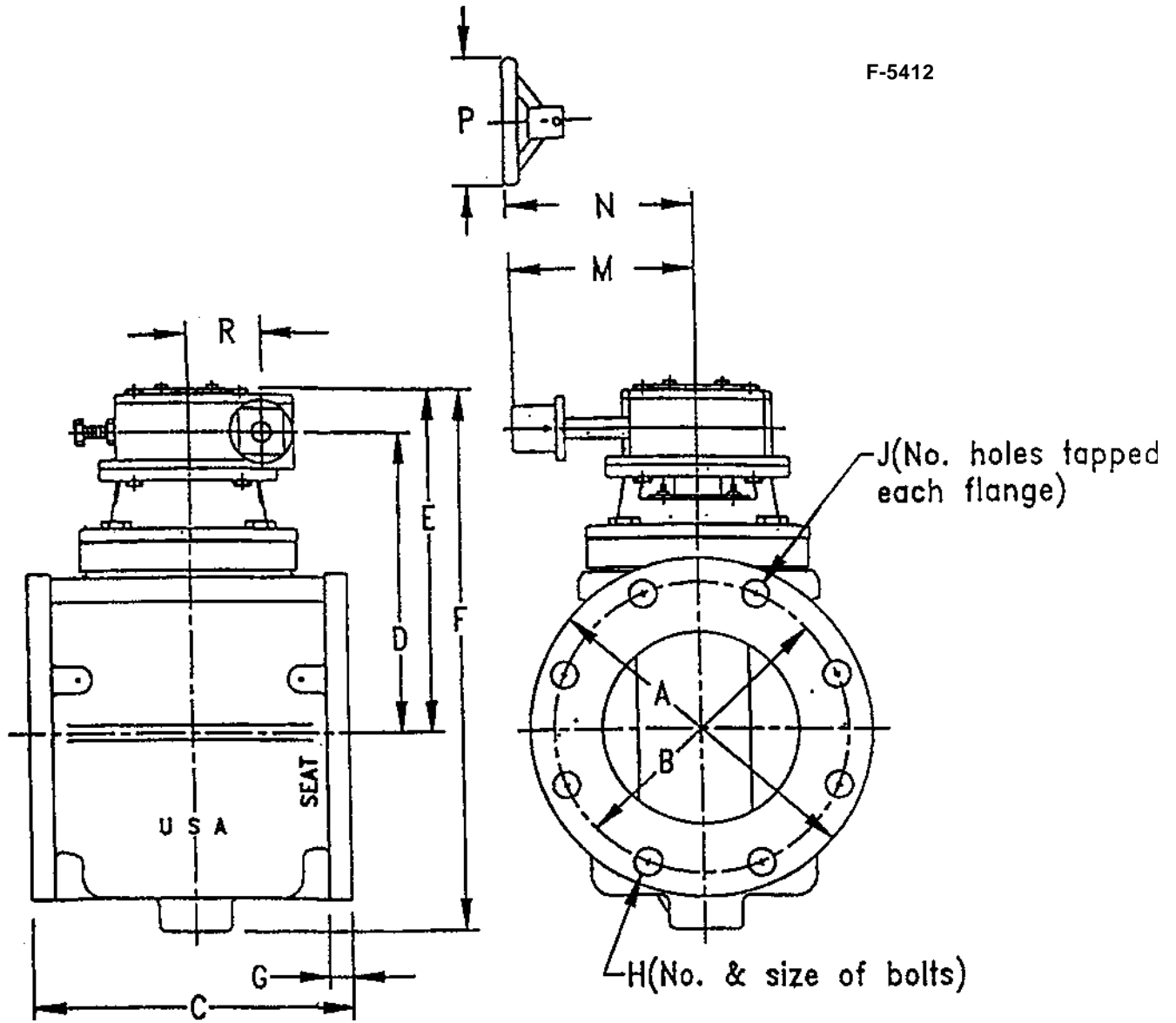

VALVE SIZE	A	B	C	D	E	F	G	H	J	M	N	P	R
4"	9	7 ¹ / ₂	9	9 ³ / ₁₆	11 ¹ / ₁₆	16 ⁷ / ₁₆	1	8— ⁵ / ₈	4	8	11	10"	3 ¹ / ₄
6"	11	9 ¹ / ₂	10 ¹ / ₂	10 ⁷ / ₈	12 ³ / ₄	19 ¹ / ₄	1 ¹ / ₁₆	8— ³ / ₄	2	8	11	10"	3 ¹ / ₄
8"	13 ¹ / ₂	11 ³ / ₄	11 ¹ / ₂	12 ³ / ₈	14 ¹ / ₄	22 ¹ / ₂	1 ³ / ₁₆	8— ³ / ₄	4	8	11	10"	3 ¹ / ₄
10"	16	14 ¹ / ₄	13	14 ¹ / ₂	16 ³ / ₈	26 ¹¹ / ₁₆	1 ¹ / ₄	12— ⁷ / ₈	4	8	11-12	10"-18"	3 ¹ / ₄
12"	19	17	14	16 ¹ / ₁₆	17 ¹⁵ / ₁₆	30	1 ¹ / ₄	12— ⁷ / ₈	4	8	11-12	10"-18"	3 ¹ / ₄
14"	21	18 ³ / ₄	17	18 ⁷ / ₈	22 ¹ / ₄	36 ⁹ / ₁₆	1 ³ / ₈	12—1	4	10	16	24"	4 ³ / ₄
16"	23 ¹ / ₂	21 ¹ / ₄	17 ³ / ₄	20 ¹ / ₁₆	23 ⁷ / ₁₆	39 ³ / ₁₆	1 ⁷ / ₁₆	16—1	6	12	18	24"	5
18"	25	22 ³ / ₄	21 ¹ / ₂	22 ¹ / ₈	25 ¹ / ₂	42 ¹¹ / ₁₆	1 ⁹ / ₁₆	16—1 ¹ / ₈	8	12	18	24"	5
20"	27 ¹ / ₂	25	23 ¹ / ₂	23 ⁷ / ₁₆	26 ¹³ / ₁₆	46 ¹³ / ₁₆	1 ¹³ / ₁₆	20—1 ¹ / ₈	8	12	18	24"	5
24"	32	29 ¹ / ₂	30	25 ¹ / ₁₆	28 ⁷ / ₁₆	51 ³ / ₈	1 ⁷ / ₈	20—1 ¹ / ₄	8	12	18	24"	5

3"-8" ECCENTRIC PLUG VALVE SMJ ENDS – GENERAL DIMENSIONS

KENNEDY VALVE

F-5413

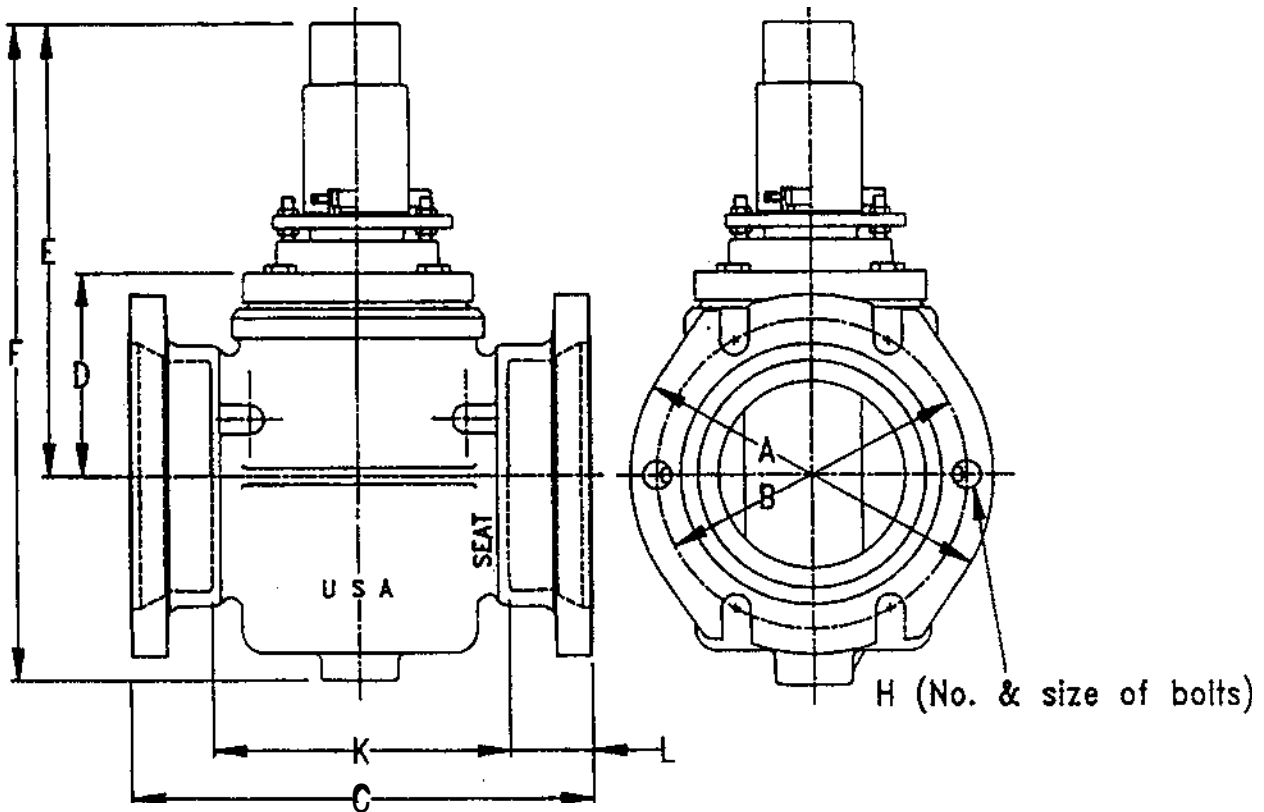

VALVE SIZE	A	B	C	D	E	F	H	K	L
3"	7 ⁵ / ₈	6 ³ / ₁₆	11 ⁷ / ₈	3 ¹⁵ / ₃₂	6 ³ / ₄	11	4— ³ / ₄	6 ⁷ / ₈	2 ¹ / ₂
4"	9 ¹ / ₈	7 ¹ / ₂	12 ¹ / ₄	4 ⁷ / ₁₆	11	16 ³ / ₈	4— ³ / ₄	7 ¹ / ₄	2 ¹ / ₂
6"	11 ¹ / ₈	9 ¹ / ₂	14 ¹ / ₈	6 ¹ / ₈	14 ¹ / ₂	21	6— ³ / ₄	9 ¹ / ₈	2 ¹ / ₂
8"	13 ³ / ₄	11 ³ / ₄	17 ¹ / ₂	7 ⁵ / ₈	16	24 ¹ / ₄	6— ³ / ₄	12 ¹ / ₂	2 ¹ / ₂

14"-24" ECCENTRIC PLUG VALVE SMJ ENDS – GENERAL DIMENSIONS

KENNEDY VALVE

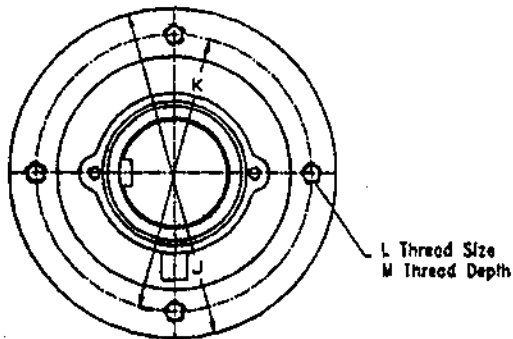

Actuator Mounting Dimensions

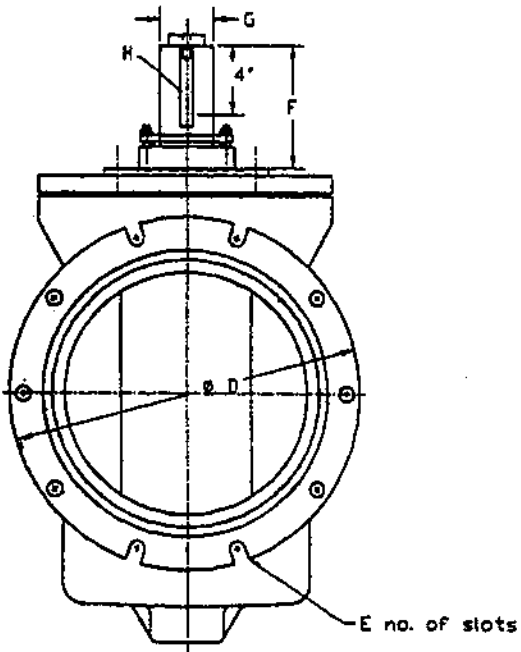
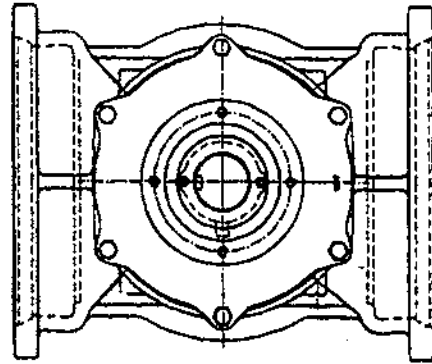

SMJ Flange Dimension
Conform to Anal 21.11/AWWA C111

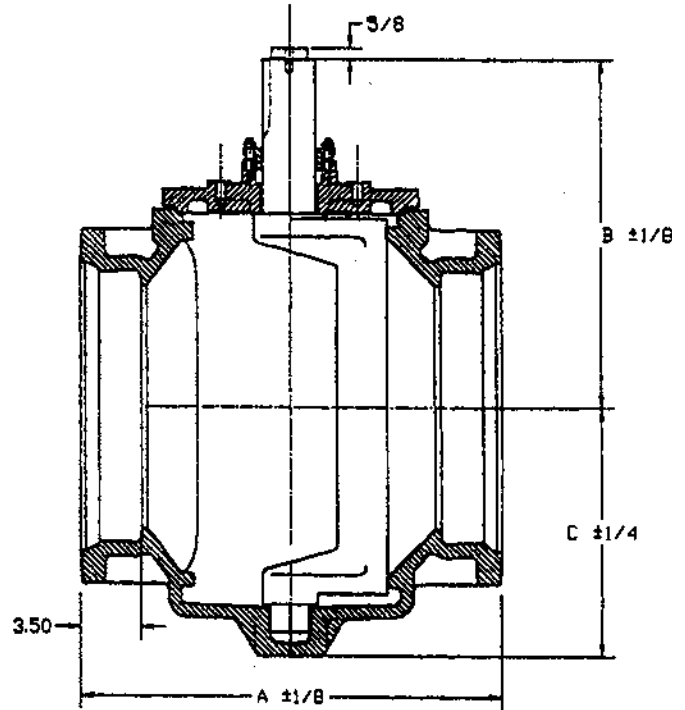

VALVE SIZE	A	B	C	D	E	F	G	H	J	K	L	M
14	24.50	19.69	14.31	20.31	4	6.81	3.121	.75 sq	9.50	8.00	5/8—11	7/8
16	24.75	20.88	15.75	22.50	4	6.81	3.121	.75 sq	9.50	8.00	5/8—11	7/8
18	28.63	22.94	17.18	24.75	4	6.81	3.121	.75 sq	9.50	8.00	5/8—11	7/8
20	30.75	24.22	20.00	27.00	2	6.81	3.121	.75 sq	9.50	8.00	5/8—11	7/8
24	37.00	25.28	22.94	31.50	2	6.81	3.750	.875 sq	11.00	9.00	3/4—10	7/8

**4"-24" ECCENTRIC PLUG VALVE
SMJ ENDS WITH WORM GEAR –
GENERAL DIMENSIONS**

KENNEDY VALVE

F-5413

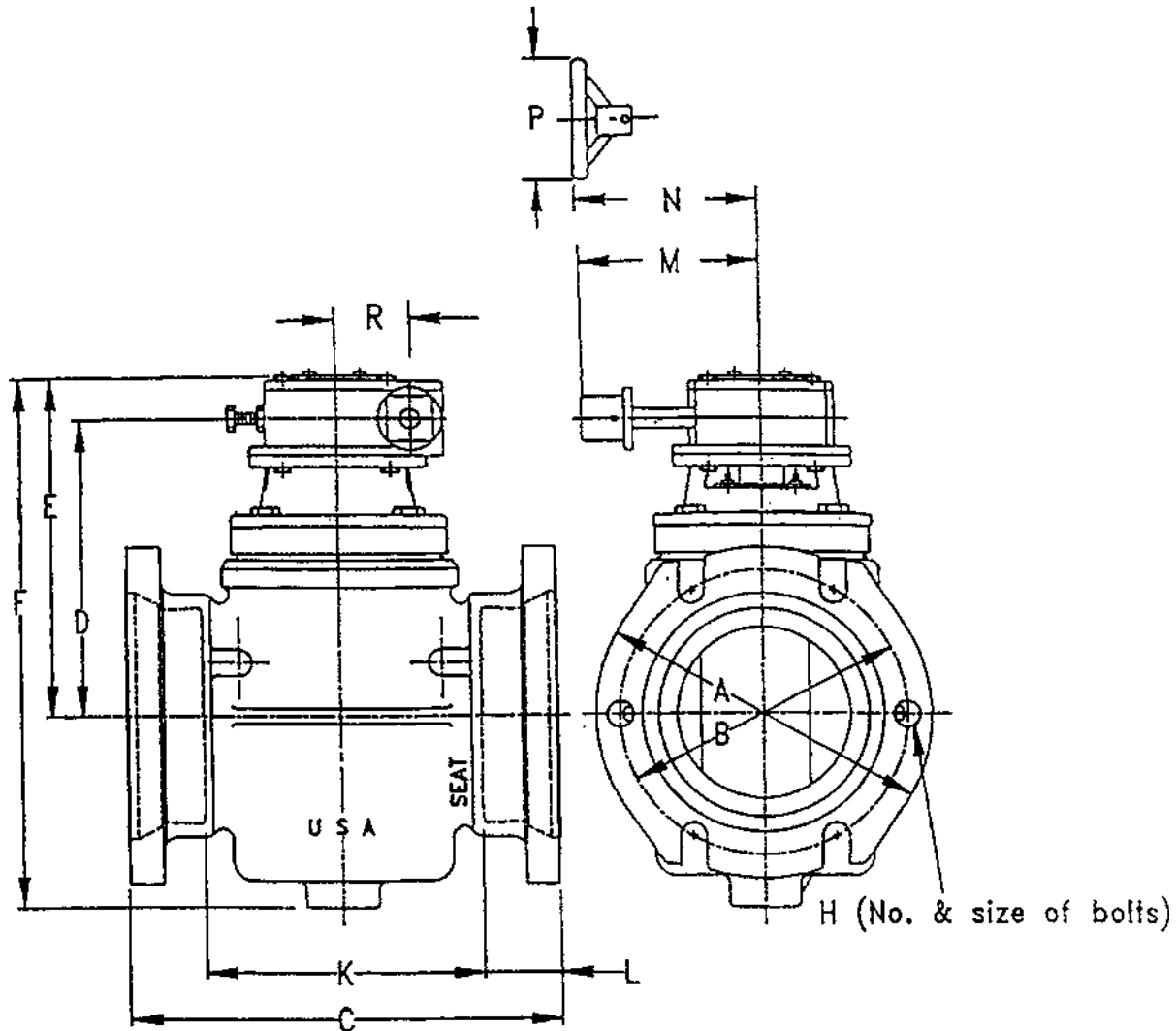

VALVE SIZE	A	B	C	D	E	F	H	K	L	M	R
4"	9 ¹ / ₈	7 ¹ / ₂	12 ¹ / ₄	9 ³ / ₁₆	11 ¹ / ₁₆	16 ⁷ / ₁₆	4— ³ / ₄	7 ¹ / ₄	2 ¹ / ₂	8	3 ¹ / ₄
6"	11 ¹ / ₈	9 ¹ / ₂	14 ¹ / ₈	10 ⁷ / ₈	12 ³ / ₄	19 ¹ / ₄	6— ³ / ₄	9 ¹ / ₈	2 ¹ / ₂	8	3 ¹ / ₄
8"	13 ³ / ₄	11 ³ / ₄	11 ¹ / ₂	12 ³ / ₈	14 ¹ / ₄	22 ¹ / ₂	6— ³ / ₄	12 ¹ / ₂	2 ¹ / ₂	8	3 ¹ / ₄
10"	15 ³ / ₄	14	19 ³ / ₈	14 ¹ / ₂	16 ³ / ₈	26 ¹¹ / ₁₆	8— ³ / ₄	14 ³ / ₈	2 ¹ / ₂	8	3 ¹ / ₄
12"	18	16 ¹ / ₄	20 ³ / ₄	16 ¹ / ₁₆	17 ¹⁵ / ₁₆	30	8— ³ / ₄	15 ³ / ₄	2 ¹ / ₂	8	3 ¹ / ₄
14"	20 ⁵ / ₁₆	18 ³ / ₄	24 ¹ / ₂	18 ⁷ / ₈	22 ¹ / ₄	36 ⁹ / ₁₆	10— ³ / ₄	17 ¹ / ₂	3 ¹ / ₂	10	4 ³ / ₄
16"	22 ¹ / ₂	21	24 ³ / ₄	20 ¹ / ₁₆	23 ⁷ / ₁₆	39 ³ / ₁₆	12— ³ / ₄	17 ³ / ₄	3 ¹ / ₂	12	5
18"	24 ³ / ₄	23 ¹ / ₂	28 ⁵ / ₈	22 ¹ / ₈	25 ¹ / ₂	42 ¹¹ / ₁₆	12— ³ / ₄	21 ⁵ / ₈	3 ¹ / ₂	12	5
20"	27	25 ¹ / ₂	30 ³ / ₄	23 ⁷ / ₁₆	26 ¹³ / ₁₆	46 ¹³ / ₁₆	14— ³ / ₄	23 ³ / ₄	3 ¹ / ₂	12	5
24"	31 ¹ / ₂	30	37	25 ¹ / ₁₆	28 ⁷ / ₁₆	51 ³ / ₈	16— ³ / ₄	30	3 ¹ / ₂	12	5

**3"-8" ECCENTRIC PLUG VALVE
GROOVED ENDS – GENERAL DIMENSIONS**

KENNEDY VALVE

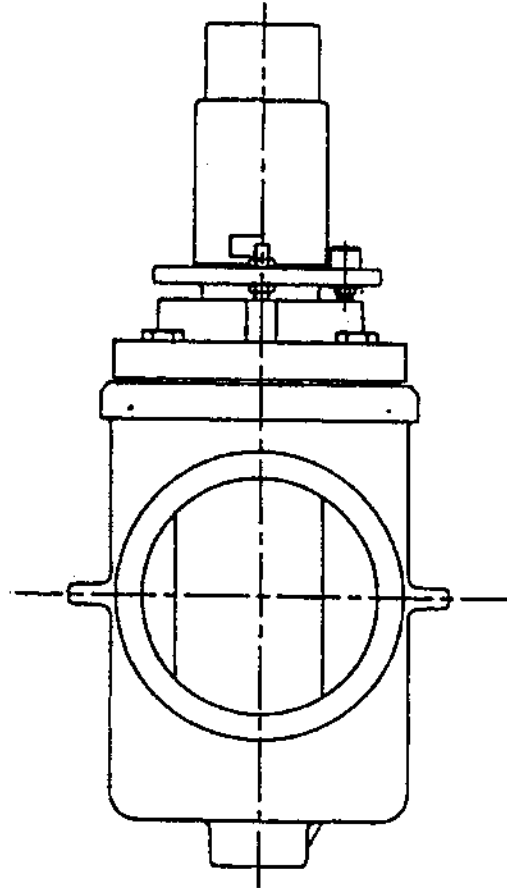
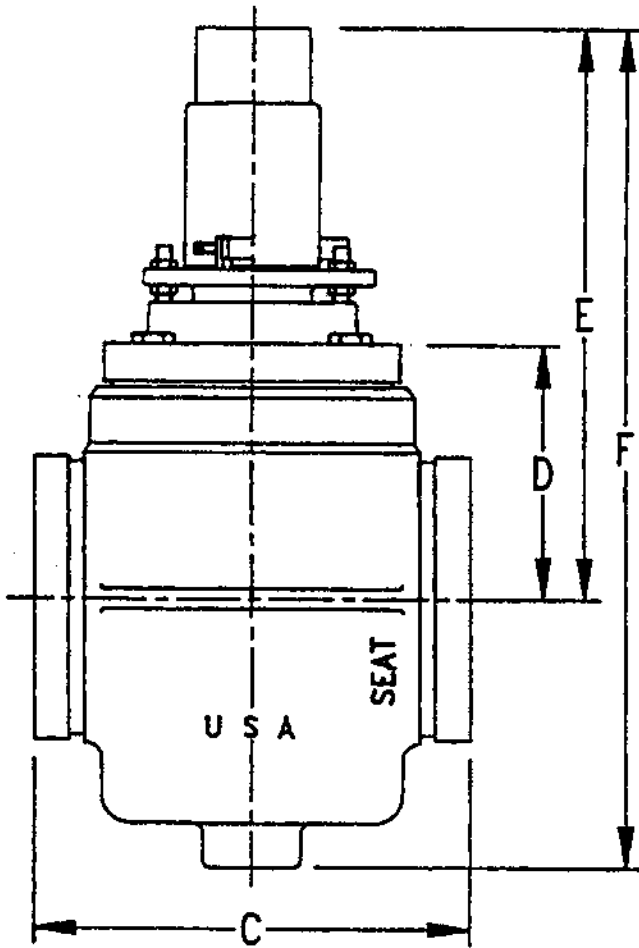

VALVE SIZE	C	D	E	F
3"	8	$3^{15}/32$	$6^{3}/4$	11
4"	9	$4^{7}/16$	11	$16^{3}/8$
6"	$10^{1}/2$	$6^{1}/8$	$14^{1}/2$	21
8"	$15^{1}/2$	$7^{5}/8$	16	$24^{1}/4$

14"-16" ECCENTRIC PLUG VALVE
GROOVED ENDS – GENERAL DIMENSIONS

KENNEDY VALVE

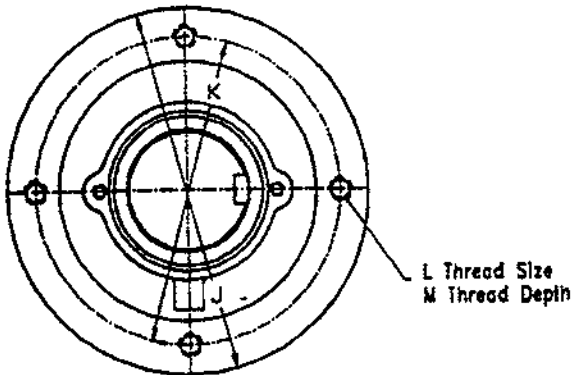

L Thread Size
M Thread Depth

Actuator Mounting Dimensions

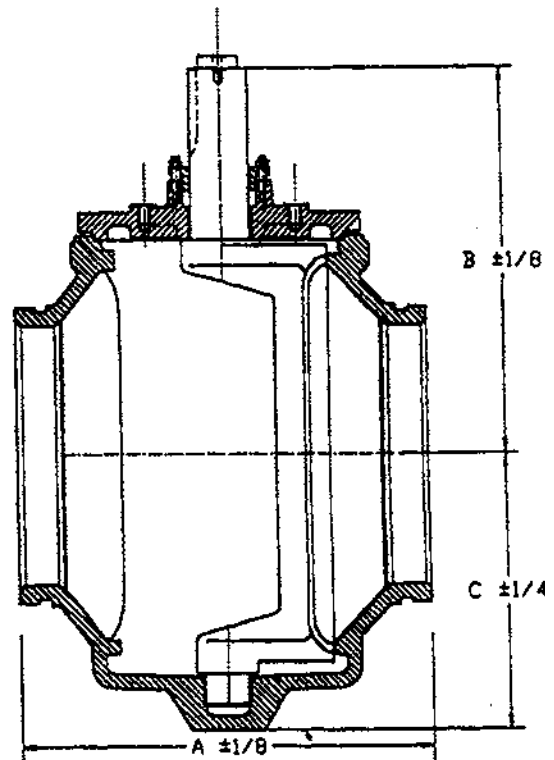
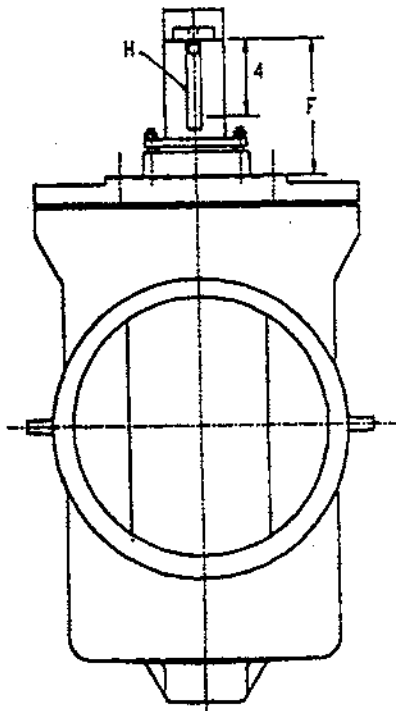
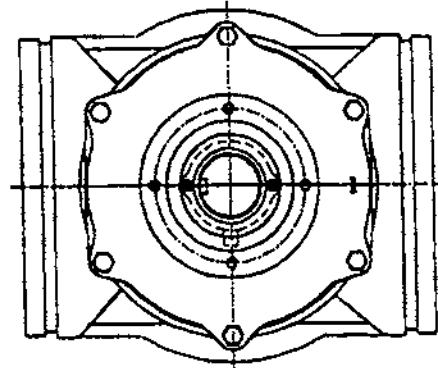

VALVE SIZE	A	B	C	F	G	H	J	K	L	M
14	21 ⁵ / ₈	19.69	14.31	6.81	3.121	.75 sq	9.50	8.00	5/8—11	7/8
16	21 ¹ / ₂	20.88	15.75	6.81	3.121	.75 sq	9.50	8.00	5/8—11	7/8

**4"-16" ECCENTRIC PLUG VALVE
GROOVED ENDS WITH WORM GEAR –
GENERAL DIMENSIONS**

KENNEDY VALVE

F-5414

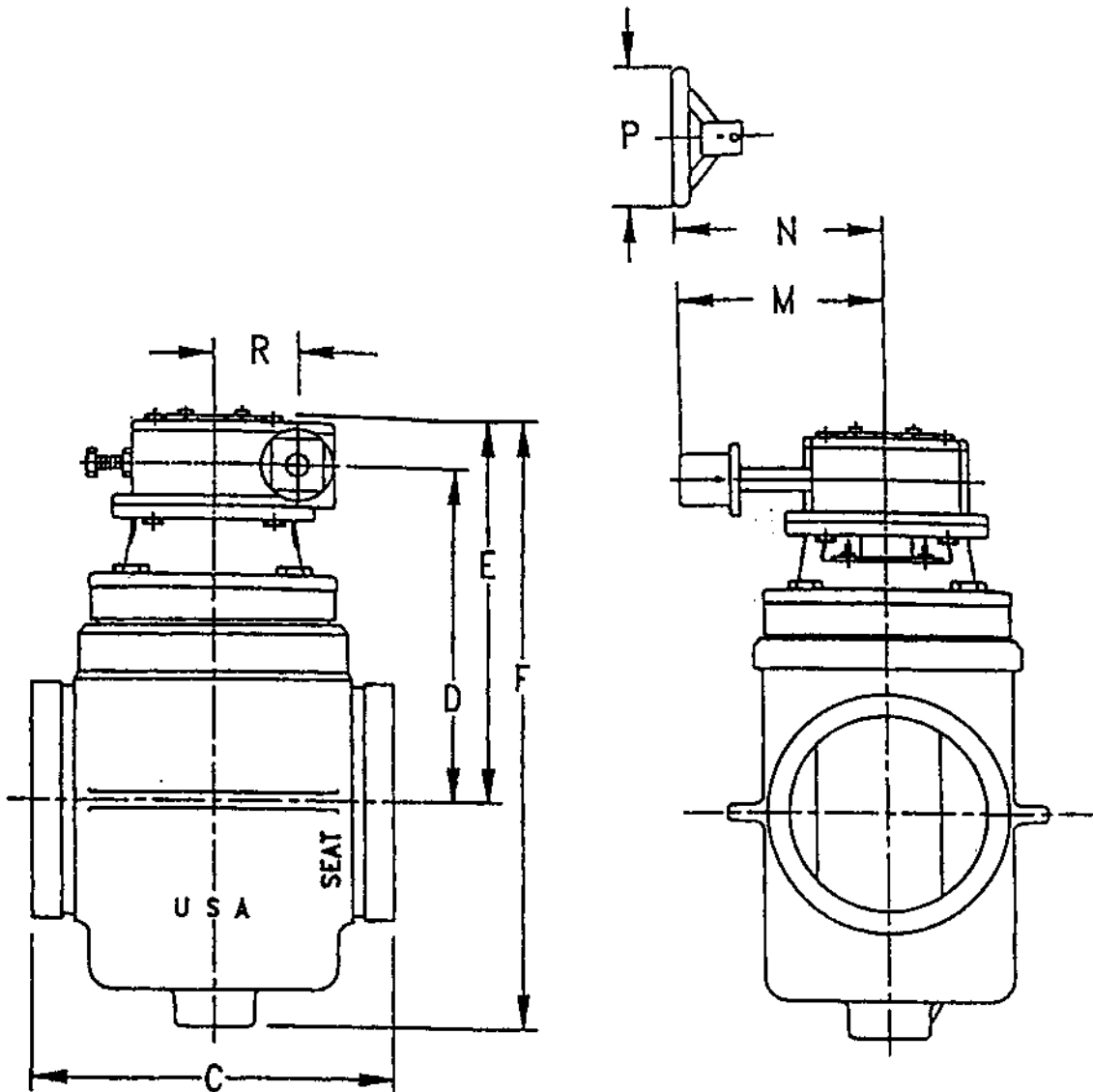

VALVE SIZE	C	D	E	F	M	N	P	R
4"	9	9 ³ / ₁₆	11 ¹ / ₁₆	16 ⁷ / ₁₆	8	11	10"	3 ¹ / ₄
6"	10 ¹ / ₂	10 ⁷ / ₈	12 ³ / ₄	19 ¹ / ₄	8	11	10"	3 ¹ / ₄
8"	15 ¹ / ₂	12 ³ / ₈	14 ¹ / ₄	22 ¹ / ₂	8	11	10"	3 ¹ / ₄
10"	17 ¹ / ₄	14 ¹ / ₂	16 ³ / ₈	26 ¹¹ / ₁₆	8	11-12	10"-18"	3 ¹ / ₄
12"	18	16 ¹ / ₁₆	17 ¹⁵ / ₁₆	30	8	11-12	10"-18"	3 ¹ / ₄
14"	21 ⁵ / ₈	18 ⁷ / ₈	22 ¹ / ₂	36 ⁹ / ₁₆	10	16	24"	4 ³ / ₄
16"	22 ¹ / ₂	20 ¹ / ₁₆	23 ⁷ / ₁₆	39 ⁹ / ₁₆	12	18	24"	5

**ECCENTRIC PLUG VALVE
MATERIALS AND SPECIFICATIONS**

KENNEDY VALVE

MATERIAL SPECIFICATIONS

CAST IRON Specification ASTM A-126 Class B

Physical Properties

Minimum tensile strength	31,000 psi
Minimum transverse strength	3,300 psi
Minimum deflection (12" centers)	.12 in.

Chemical Analysis (percent)

Phosphorus (maximum)	.75
Sulfur (maximum)	.12

STAINLESS STEEL – 316 – ASTM A743 Grade CF-8M

Physical Properties

Ultimate tensile strength	70,000 psi
Yield strength	30,000 psi
Elongation	30%
Rockwell hardness	B50

Chemical Analysis (percent)

Chromium	19
Nickel	9.0-12.0
Molybdenum	2.0-3.0
Silicon	2.0

BUNA-N RUBBER (Acrylonitrile-Butadiene)

Physical and Mechanical Properties

Tensile strength	1,475 psi
Elongation	238%
Hardness (Shore A)	70
Compression set (Method B, 22 hrs. @ 150 F.)	18.7%
Specific Gravity	1.24

**4"-12" ECCENTRIC PLUG VALVE
FULL PORT GEARED GENERAL DIMENSIONS**

KENNEDY VALVE

MODEL 2725

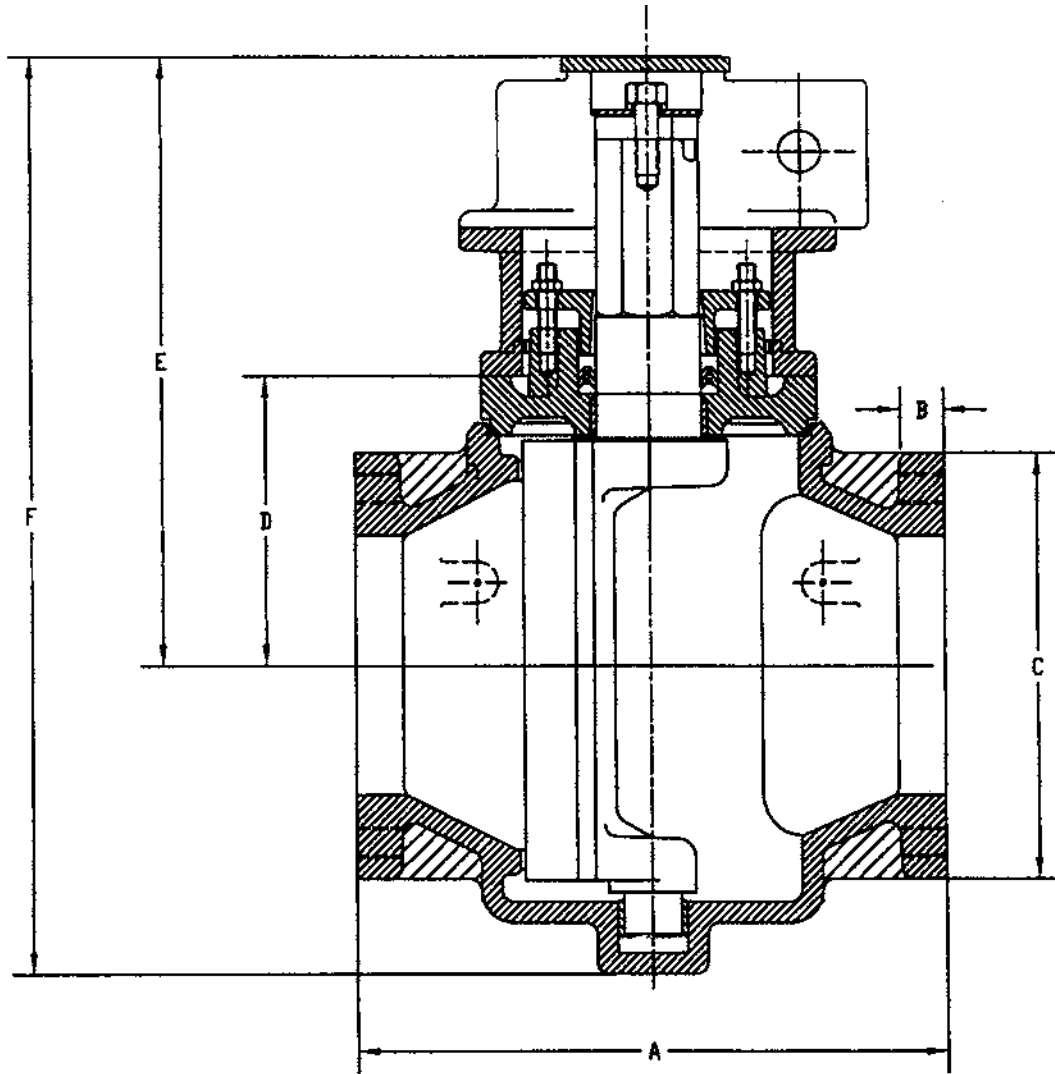

	3"	4"	6"	8"	10"	12"
A	10-5/16	12-1/2	13-1/2	18	18	22
B	3/4	1	1-1/16	1-3/16	1-3/16	1-1/4
C	7-1/2	9	11	13-1/2	16	19
D	4-7/16	6-1/8	7-5/8	9-3/8	10-3/4	12-7/16
E	11-3/16	12-7/8	14-3/8	16-1/8	17-1/2	19-3/16
F	16-9/16	19-3/8	22-5/8	26-7/16	29-13/16	33-1/2

**4"-12" ECCENTRIC PLUG VALVE
FULL PORT GEARED MATERIAL LIST**

KENNEDY VALVE

MODEL 2725

Item	Description	Material	Qty.
1	Manual Gear Actuator	--	1
2	Cover Kit (above ground) w/(2) 10-24 x 1/2 screws Cover Kit (buried) w/ screws & Gasket		1
* 3	Hex Hd Capscrew	Steel-Zinc Plated	2
* 4	Lock Washer 1/2"	Steel-Zinc Plated	1
* 5	Heavy Flat Washer	Steel-Zinc Plated	1
* 6	Cover Studs	Steel-Zinc Plated	2
* 7	Cover Stud Hex Nuts	Steel-Zinc Plated	2
8	Follower Gland	Gray Iron ASTM A126 C1 B	1
9	"V" Rings Seal	Buna N	1 set
10	Upper Sleeve Bearing	Oil Impregnated 316 Stainless Steel	1
11	Cover	Gray Iron ASTM A126 C1 B	1
* 12	Hexagon Cover Bolts	Steel-Zinc Plated	
13	Thrust Washer	Nylatron	1
14	Cover "O" Ring	Buna N	1
15	Body - Flanged	Gray Iron ASTM A126 C1 B	1
16	Plug	Buna N	1
17	Lower Sleeve Bearing	316 Stainless Steel 10" & 12"	1 2
18	Gear Adapter (above ground) (buried)	Gray Iron ASTM A126 C1 B	1
* 19	Hex Hd Capscrew for gear actuator	Steel-Zinc Plated 10KE100 uses 8	4
* 20	Hex Hd Capscrew for adapter	Steel-Zinc Plated	noted
21	Groov Pin	303 Stainless Steel	1
22	2" Sq. Operating Nut	Gray Iron ASTM A126 C1 B	1
	Handwheel	Gray Iron ASTM A126 C1 B	1
	Cover Plug	1/2" NPT steel plug	

* Item can be supplied in stainless steel upon request
Interior and exterior ferrous metal surfaces can be epoxy coated to comply with the AWWA C550 Standard upon request.
Other coatings available upon request.

Valves are rated for 175 psig system pressure.
Valve sealing port area greater than pipeline area.

Full port valves available in flange ends only.

4"-12" ECCENTRIC PLUG VALVE
FULL PORT GEARED MATERIAL DRAWING

KENNEDY VALVE

MODEL 2725

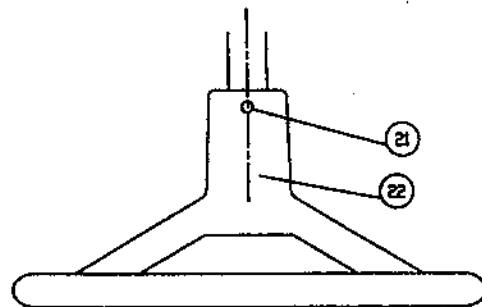
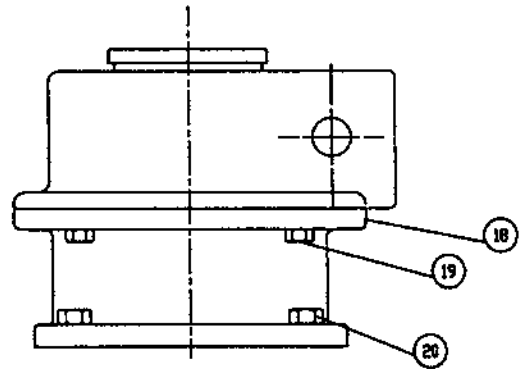
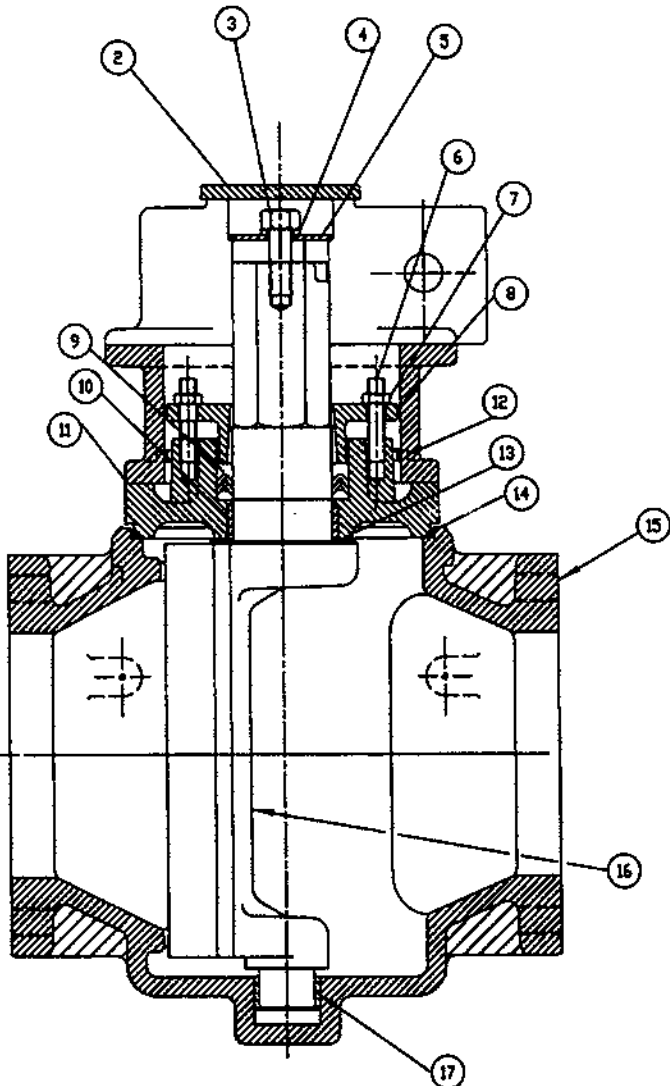
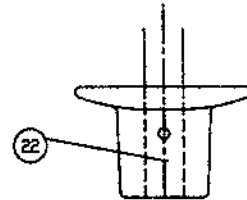
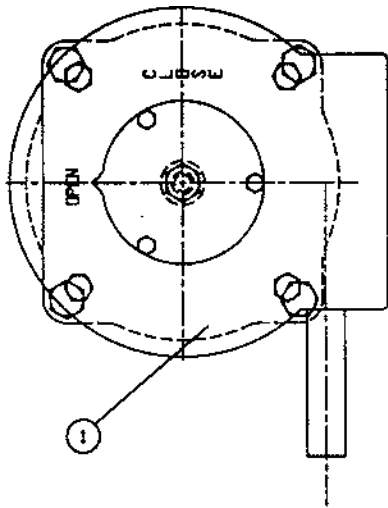

**4"-12" ECCENTRIC PLUG VALVE
FULL PORT GEARED MATERIAL LIST**

KENNEDY VALVE

MODEL 2725

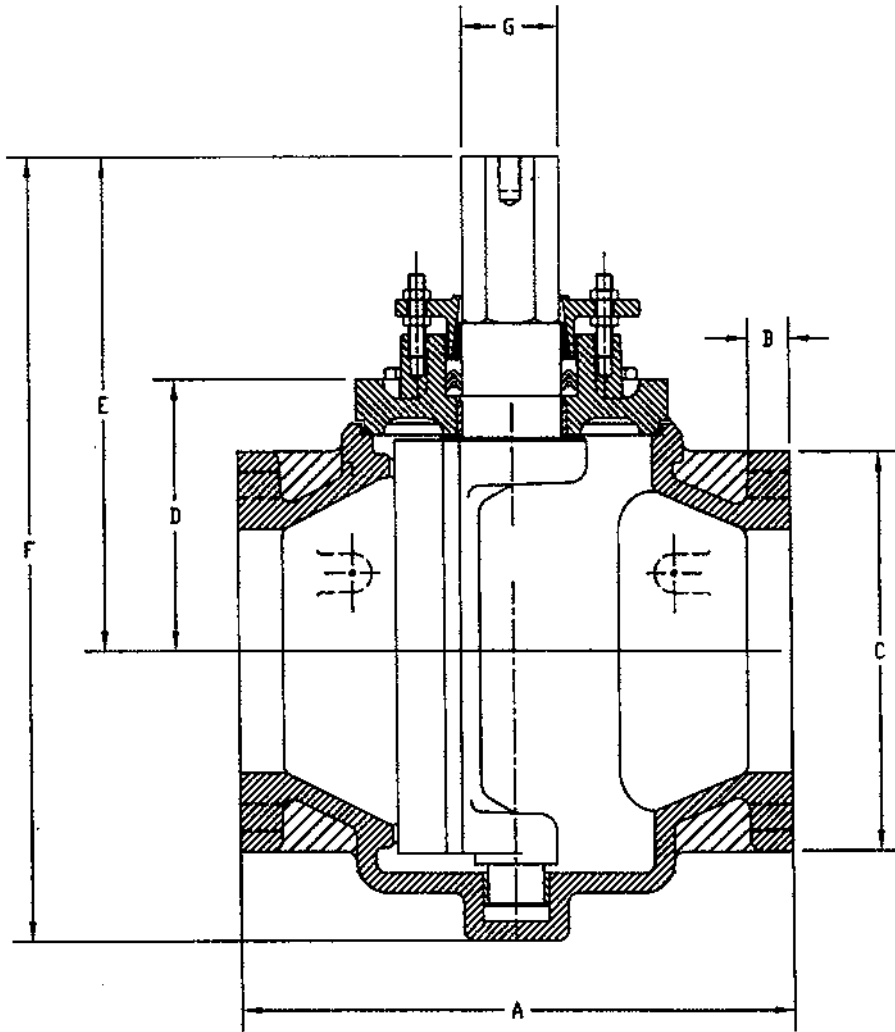

	3"	4"	6"	8"
A	10-5/16	12-1/2	13-1/2	18
B	3/4	1	1-1/16	1-3/16
C	7-1/2	9	11	13-1/2
D	4-7/16	6-1/8	7-5/8	9-3/8
E	7-5/8	11-1/16	12-13/16	14-11/16
F	13	17-9/16	21-1/16	25
G	1.748	2.247	2.247	2.746

**3"-8" ECCENTRIC PLUG VALVE
FULL PORT MATERIAL LIST**

KENNEDY VALVE

MODEL 2725

Item	Description	Material	Qty.
1	2" Sq. Operating Nut	Gray Iron ASTM A126 C1 B	1
	Lever Operator - 3" only	Gray Iron ASTM A126 C1 B	1
* 2	Plug Stem Stud	Steel-Zinc Plated	1
* 3	Hex Locking Nut	Steel-Zinc Plated	2
4	Disc Spring Washer	Steel-Zinc Plated	5
* 5	Cover Studs	Steel-Zinc Plated	2
* 6	Cover Stud Hex Nuts	Steel-Zinc Plated	4
* 7	Follower Guard	Gray Iron ASTM A126 C1 B	1
8	Brake	PPS 40% glass filled	1
9	"V" Rings Seala-4" - 12" "O" Rings Seals-3" only	Buna N Buna N	1 set 2
10	Upper Sleeve Bearing	Oil Impregnated 316 Stainless Steel	1
11	Cover	Gray Iron ASTM A126 C1 B	1
* 12	Hexagon Cover Bolts	Steel-Zinc Plated	
13	Thrust Washer	Nylatron	1
14	Cover "O" Ring	Buna N	1
15	Body - Flanged	Gray Iron ASTM A126 C1 B	1
16	Plug	Buna N or Chlorobutyl Isoprene	1
17	Lower Sleeve Bearing	Oil Impregnated 316 Stainless Steel	1 2
* 18	5/16" Hex Jaw Nut	Steel-Zinc Plated	1
* 19	Follower Sq Hd Set Screw	Steel-Zinc Plated	1
* 20	Socket Hd Capscrew	Steel	1
* 21	Washer	Steel	1
	2" Sq. Operating Nut	Gray Iron ASTM A126 C1 B	1
* 22	Hex Jam Nut	Steel-Zinc Plated	1
23	Memory Stop- 3" only	Gray Iron ASTM A126 C1 B	1
* 24	Hex Capscrew for 3" EPV (2" sq. Operat'g Nut)	Steel-Zinc Plated	1
	Hex Capscrew for 3" EPV (Hand Lever)	Steel-Zinc Plated	1

* Item can be supplied in stainless steel upon request

Interior and exterior ferrous metal surfaces can be epoxy coated to comply with the AWWA C550 Standard upon request.

Other coatings available upon request.

Valves are rated for 175 psig system pressure.

Valve sealing port area greater than pipeline area.

Full port valves available in flange ends only.

**3"-8" ECCENTRIC PLUG VALVE
FULL PORT GEARED MATERIAL DRAWING**

KENNEDY VALVE

MODEL 2725

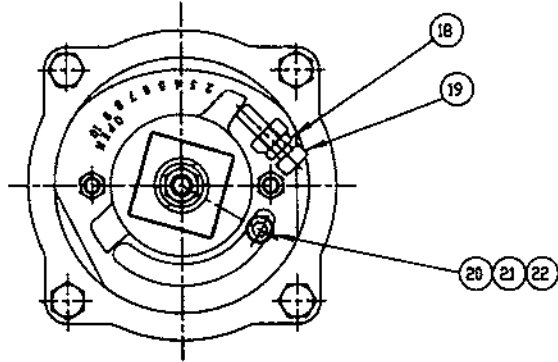

Top View Sizes 4' thru 8'

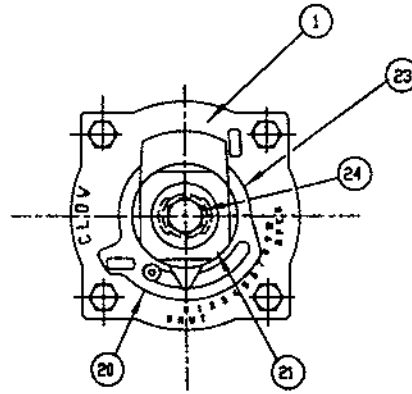

Top View Size 3'

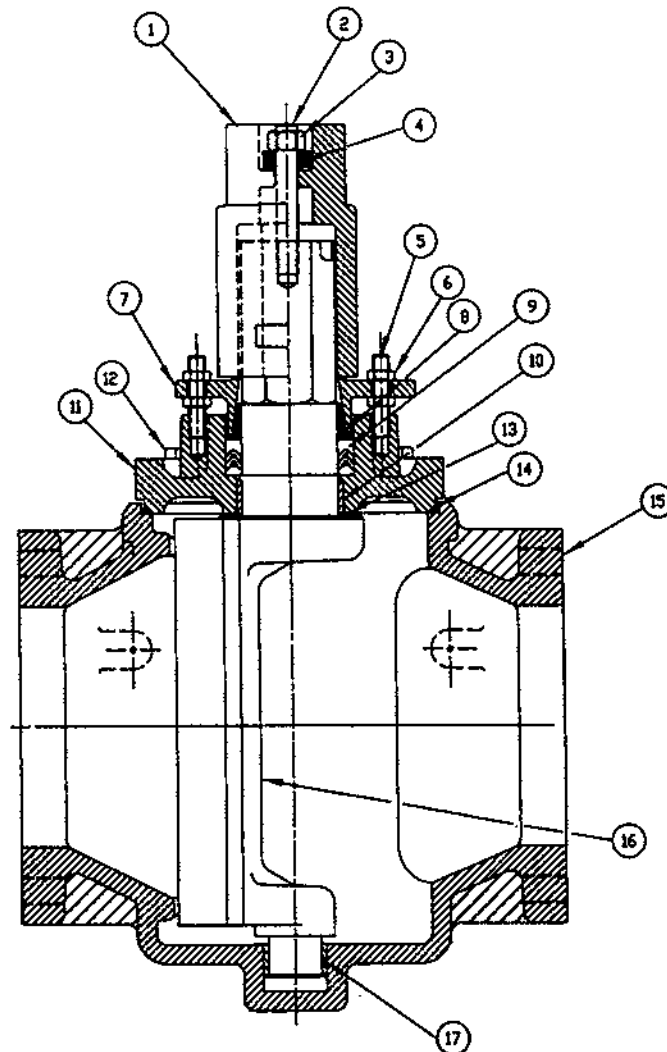

ECCENTRIC PLUG VALVE FEATURES AND BENEFITS

KENNEDY VALVE

- 1. Stem Packing Seals** – Kennedy utilizes Buna-N multiple “V” ring stem packing seals. This sealing system conforms to AWWA C504 and AWWA C507 standards. The Kennedy valve is repackable while under pressure without removing the actuation. The packing seal is held in place with an adjustable gland follower to provide many years of reliable service.
- 2. Bolted Bonnet** – Valve bonnets are fully sealed and securely bolted to the valve body for easy removal of the plug should maintenance be required.
- 3. Shaft Bearings** – Sintered 316 stainless steel shaft bearings are used in the upper and lower tunnions. These bearings are permanently lubricated for ease of operation even after long periods of inactivity.
- 4. Valve Body** – The body and cover of the Kennedy valve is cast iron (Semi-Steel) conforming to ASTM A126 Class B. Flanged valves are in full compliance with ANSI B16.1 Class 125 standards including flange thickness. Mechanical Joint valves are in compliance with AWWA C111/ANSI 21.11. Grooved End valves are in compliance with AWWA C606.
- 5. Welded Nickel Seat** – Kennedy welds a corrosion resistant nickel seat to a raised area in the body. The weld is of 90% pure nickel, at least 1/8" thick after it is machined. The nickel covers the entire seat surface so that there is no possibility of corrosion that could damage the plug face.
- 6. Plug** – The valve plug is cast iron ASTM A126, Class B. The portion of the plug in the valve body cavity is coated with Buna-N rubber using an injection molding process. This allows for the entire surface to be covered, not just the plug face. With this injection molding process, you do not have to worry about the rubber dis-bonding from the iron.
- 7. O-Ring Bonnet Seal** – The seal between the body and bonnet is an O-Ring allowing for easier maintenance, and since O-Rings seal better than flat gaskets, the number of bonnet bolts is reduced.

3"-24" ECCENTRIC PLUG VALVE OPERATING ACTION

KENNEDY VALVE

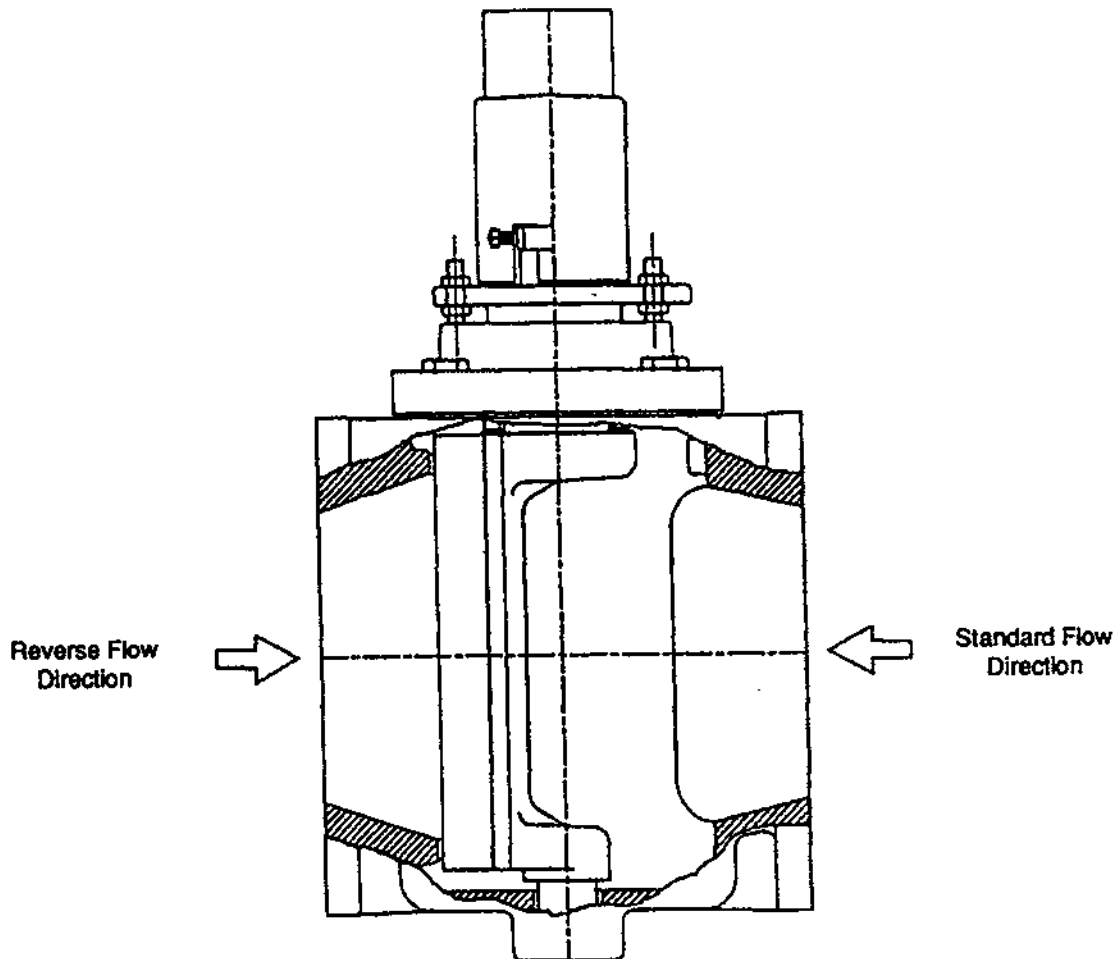

FLOW DIRECTION DESIGNATION

FLOW DIRECTION DESIGNATION

Valves 3" through 8" are available with lever actuators. Geared actuators are recommended on 6" and larger valves. It is also recommended that valves installed in pipelines with high velocity or where water hammer conditions can be caused by sudden valve shut-off that geared actuators be installed. Lever actuators can only be used for pressure ratings of 100 psi maximum and 25 psi in the reverse flow conditions.

ECENTRIC PLUG VALVE FLOW DESIGNATED

KENNEDY VALVE

CLOSED

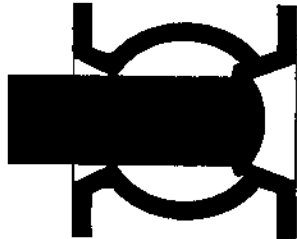

As the plug component is rotated to valve closure, the offset condition of the plug causes the seating surface to move axially downstream into the nickel. The results in a high seating force thereby crushing trapped solids and resulting in a bubble-tight seal. The upstream pressure acting on the convex side of the plug further improves the bubble-tight seal.

OPENING



Upon opening the valve, the initial rotation of the plug causes the resilient seating surface to move axially away from the nickel seat in the body. This action minimizes wear and scraping of the resilient seat, thereby improving the life of the valve. The plug can be positioned at any position between open and closed for throttling applications.

OPEN



In the full-open position, the plug is rotated out of the main fluid stream as shown. This allows for high capacity flow through the valve.

**ECCENTRIC PLUG VALVE
C_v VALUES**

KENNEDY VALVE

VALVE SIZE	PORT AREA %	C _v
3"	85	335
4"	88	565
6"	87	1210
8"	89	2050
10"	81	3100
12"	84	4170
14"	84	5460
16"	84	7420
18"	83	9675
20"	89	12920
24"	71	17670

Flow in GPM (gallons per minute) to equal a 1 psi pressure drop

Sizing Formula

Symbol Definitions

$$(1) C_v = \frac{Q}{\sqrt{\Delta P}}$$

C_v = Valve Sizing Coefficient

$$(2) Q = C_v \sqrt{\Delta P}$$

ΔP = Pressure drop, pounds per square inch (psi)

$$(3) \Delta P = \left(\frac{Q}{C_v}\right)^2$$

Q = Flow, gallons per minute (gpm)

**4"-24" ECCENTRIC PLUG VALVE
WORM GEAR ACTUATOR SELECTION CHART**

KENNEDY VALVE

**Gear operators with 2" sq. operating nuts, 150 ft. – lb. max. input torque
Consult factory for Reverse Flows above 50 psig.**

VALVE SIZE	50 psig	75 psig	100 psig	125 psig	150 psig	175 psig
4"	U10N	U10N	U10N	U10N	U10N	U10N
6"	U10N	U10N	U10N	U10N	U10N	U10N
8"	U10N	U10N	U10N	U10N	U10N	U10N
10"	U10N	U10N	U10N	U10N	U10N	U10N
12"	U10N	U10N	U10N	U10N	U10N	U10N
14"	U90N	U90N	U90N	U90N	U90N	—
16"	U90N	U90N	U90N	U90N	U100N	—
18"	U100N	U100N	U100N	U100N	U100N	—
20"	U100N	U100N	U100N	U100N	U100N	—
24"	U100N	U100N	U100N	U160N	U160N	—

U10N = 1KE/OP Nut Buried Service

U90N = 9KE/OP Nut Buried Service

U100N = 10KE 2.5/OP Nut Buried Service

U160 = 16KE/OP Nut Buried Service

**Gear operators with Handwheels & 80 lb. max. rim pull
Consult factory for Reverse Flows above 50 psig.**

VALVE SIZE	50 psig	75 psig	100 psig	125 psig	150 psig	175 psig
4"	A110	A110	A110	A110	A110	A110
6"	A110	A110	A110	A110	A110	A110
8"	A110	A110	A110	A110	A110	A110
10"	A118	A118	A118	A118	A118	A118
12"	A118	A118	A118	A118	A118	A118
14"	A924	A924	A924	A924	A930	—
16"	A1024	A1024	A1024	A1024	A1624	—
18"	A1024	A1024	A1024	A1030	A1624	—
20"	A1024	A1024	A1030	A1624	A1624	—
24"	A1024	A1030	A1624	A1630	A1630	—

A110 = 1KE/10" Handwheel

A118 = 1KE/18" Handwheel

A924 = 9KE/24" Handwheel

A930 = 9KE/30" Handwheel

A1024 = 10KE 2.5/24" Handwheel

A1030 = 10KE 2.5/30" Handwheel

A1624 = 10KE 6/24" Handwheel

A1630 = 16KE/30" Handwheel

**4"-24" ECCENTRIC PLUG VALVE
OPERATION ORIENTATION OPTION**

KENNEDY VALVE

OPTIONAL MOUNTING POSITION

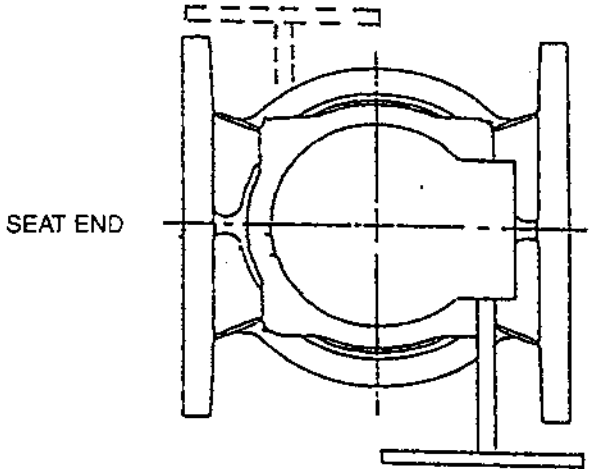

STANDARD MOUNTING POSITION

ACTUATOR MOUNTING POSITION AS VIEWED
FROM THE TOP OF THE VALVE

3"-24" ECCENTRIC PLUG VALVE ACCESSORIES – REMOTE EQUIPMENT

KENNEDY VALVE

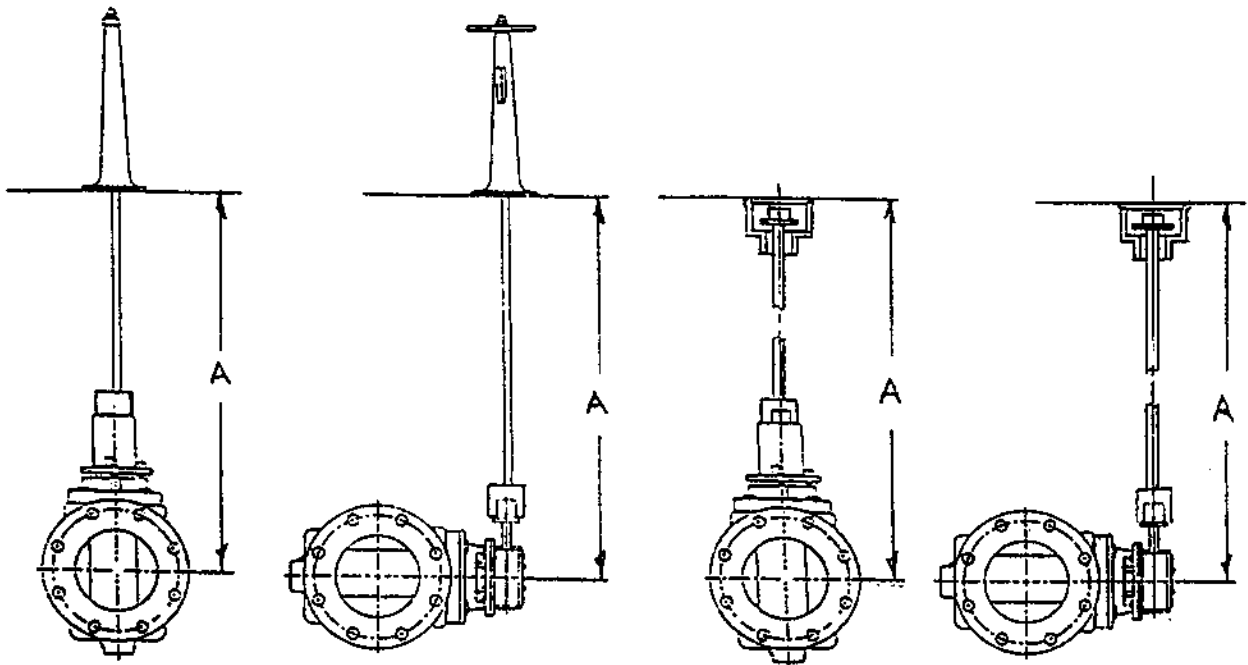

FLOORSTAND
INSTALLATION
WRENCH OPERATED
VALVE

INDICATING FLOORSTAND
INSTALLATION - GEAR
ACTUATED VALVE

FLOORBOX
INSTALLATION
WRENCH OPERATED
VALVE

FLOORBOX
INSTALLATION
GEAR ACTUATED
VALVE

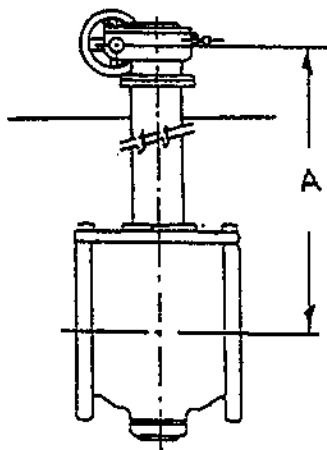

EXTENDED BONNET ASSEMBLY VALVES FOR
BURIED OR SUBMERGED SERVICE. CAN BE
FURNISHED WITH HANDWHEEL/GEAR,
CYLINDER OR ELECTRICAL ACTUATOR.

"A" TO BE SPECIFIED BY THE CONTRACTOR FOR
PROPER SIZING OF EXTENSION ASSEMBLY.

ECCENTRIC PLUG VALVE SPECIFICATIONS

KENNEDY VALVE

Eccentric Plug Valves shall be of the tight closing, resilient faced, non-lubricating variety and shall be of eccentric design such that the valves pressure member (plug) rises off the body seat contact area immediately upon shaft rotation during the opening movement. Valves shall be drop-tight at the rated pressure (175 psi through 12", 150 psi 14" and above) and shall be satisfactory for applications involving throttling service as well as frequent or infrequent on-off service. The valve closing member should rotate approximately 90 degrees from the full-open to full-close position and vice-versa.

The valve body shall be constructed of cast iron (semi-steel) conforming to ASTM A126, Class B. Body ends shall be:

- 1) Flanged with dimensions, facing, and drilling in full conformance with A – ANSI B16.1, Class 125. This includes Flange Thickness.
- 2) Mechanical Joint to meet the requirements of AWWA C111/ANSI A21.11.
- 3) Grooved ends to meet the requirements of AWWA C606.

Eccentric Plug Valves shall have a rectangular shaped port. Port areas for 3"-20" valves shall be a minimum 80% of full pipe area.

Valve seat surface shall be welded-in overlay, cylindrically shaped of not less than 90% pure nickel. Seat area shall be raised, with raised area completely covered with weld to insure proper seat contact. The machined seat area shall be a minimum of .125 thick and .500" wide.

The valve plug shall be constructed of cast iron (semi-steel) conforming to ASTM – A126, Class B. The plug shall have a cylindrical seating surface that is offset from the center of the plug shafts. The plug shafts shall be integral. The entire plug shall be 100% encapsulated with Buna-N rubber in all valve sizes. The rubber compound shall be approximately 70 (Shore A) durometer hardness. The Rubber to metal bond must withstand 75 lbs. pull under test procedure ASTM D – 429 – 73 Method B.

Shaft bearings, upper and lower, shall be sleeve type metal bearings, sintered, oil impregnated, and permanently lubricated type 316 stainless steel conforming to ASTM A743 Grade CF-8M. Thrust bearings shall be Nylatron.

Plug valve shaft seals shall be of the multiple V-ring type (Chevron) and shall be adjustable. All packing shall be replaceable without removing the bonnet or actuator and while the valve is in service. Shaft seals shall be made of Buna N.

Each valve shall be given a test against the seat at the full rated working pressure and a hydrostatic shell test at twice the rated working pressure. Certified copies of individual tests shall be submitted when requested. Certified copies of proof-of-design tests shall be submitted upon request.

Manual valves shall have lever or worm gear type actuators with handwheels, 2" square nuts, or chainwheels attached. Lever actuators shall be furnished on valves 8" and smaller where the maximum unseating pressure is 25 psig or less. Worm gear type actuators shall be furnished on all 4" or larger valves where the maximum unseating pressure is 25 psig or more.

All eccentric plug valves shall be Kennedy F5412 (Flanged), F5413 (Mechanical Joint), or F5414 (Grooved) or approved equal.