

INDICATOR POST STYLE 2945 A TELESCOPING BARREL ASSEMBLY UL AND FM APPROVED

KENNEDY VALVE

Available in Sizes B C D E
See Page 6 for Dimensions

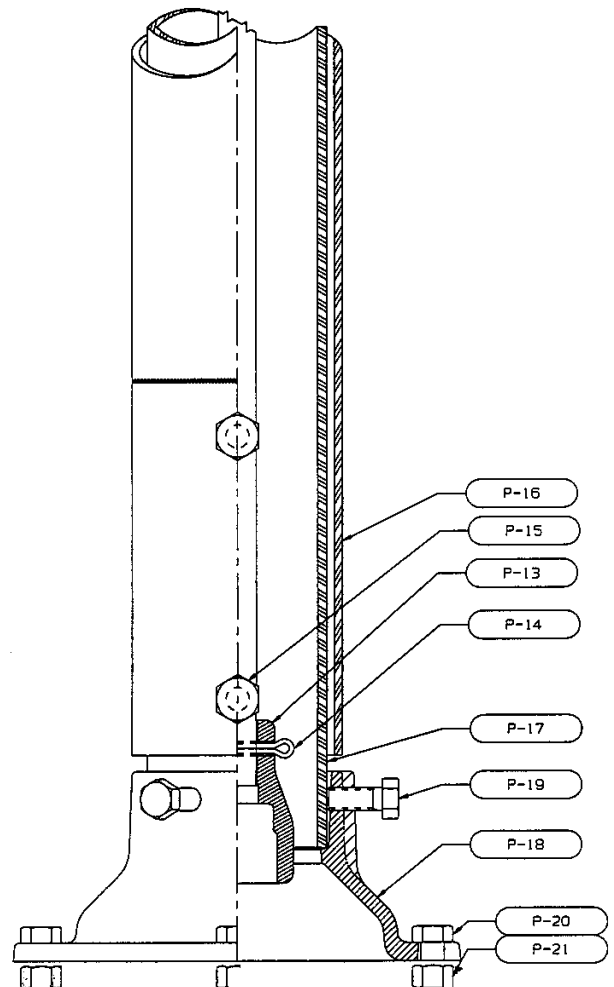
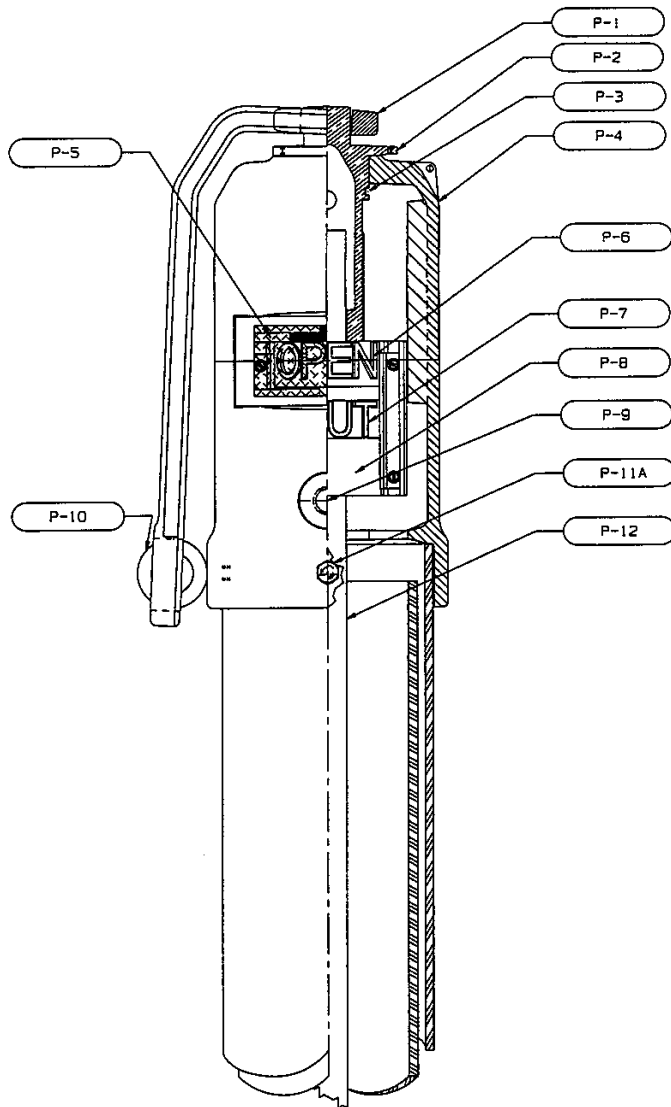

INDICATOR POST STYLE 2945 A TELESCOPING BARREL UL/FM DIMENSIONS AND INSTRUCTIONS

KENNEDY VALVE

Available in Sizes B C D E
See Page 6 for Dimensions

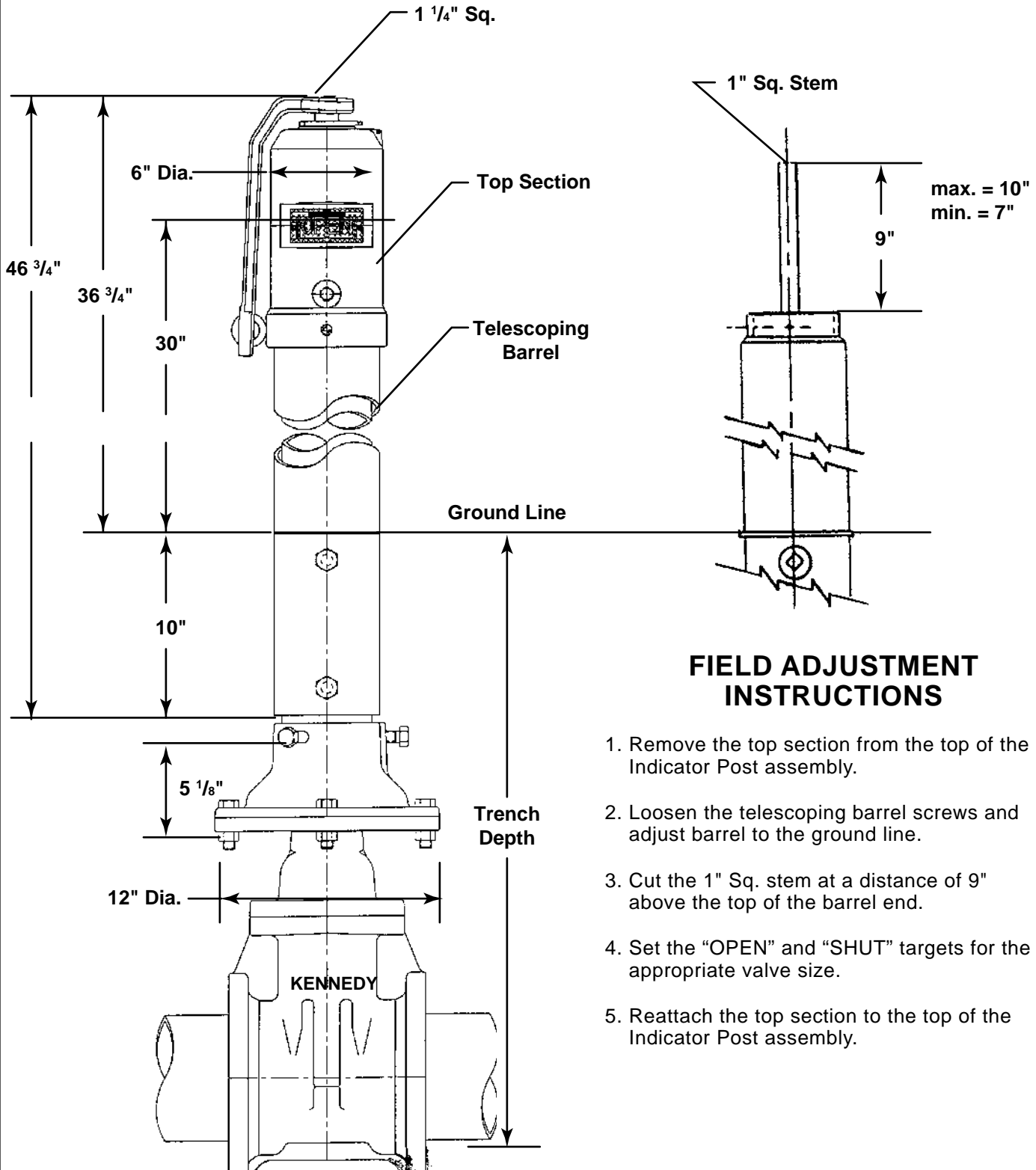

**INDICATOR POST STYLE 2945
FIXED LENGTH ASSEMBLY
UL AND FM APPROVED**

KENNEDY VALVE

Available in Sizes F G H
See Page 6 for Dimensions

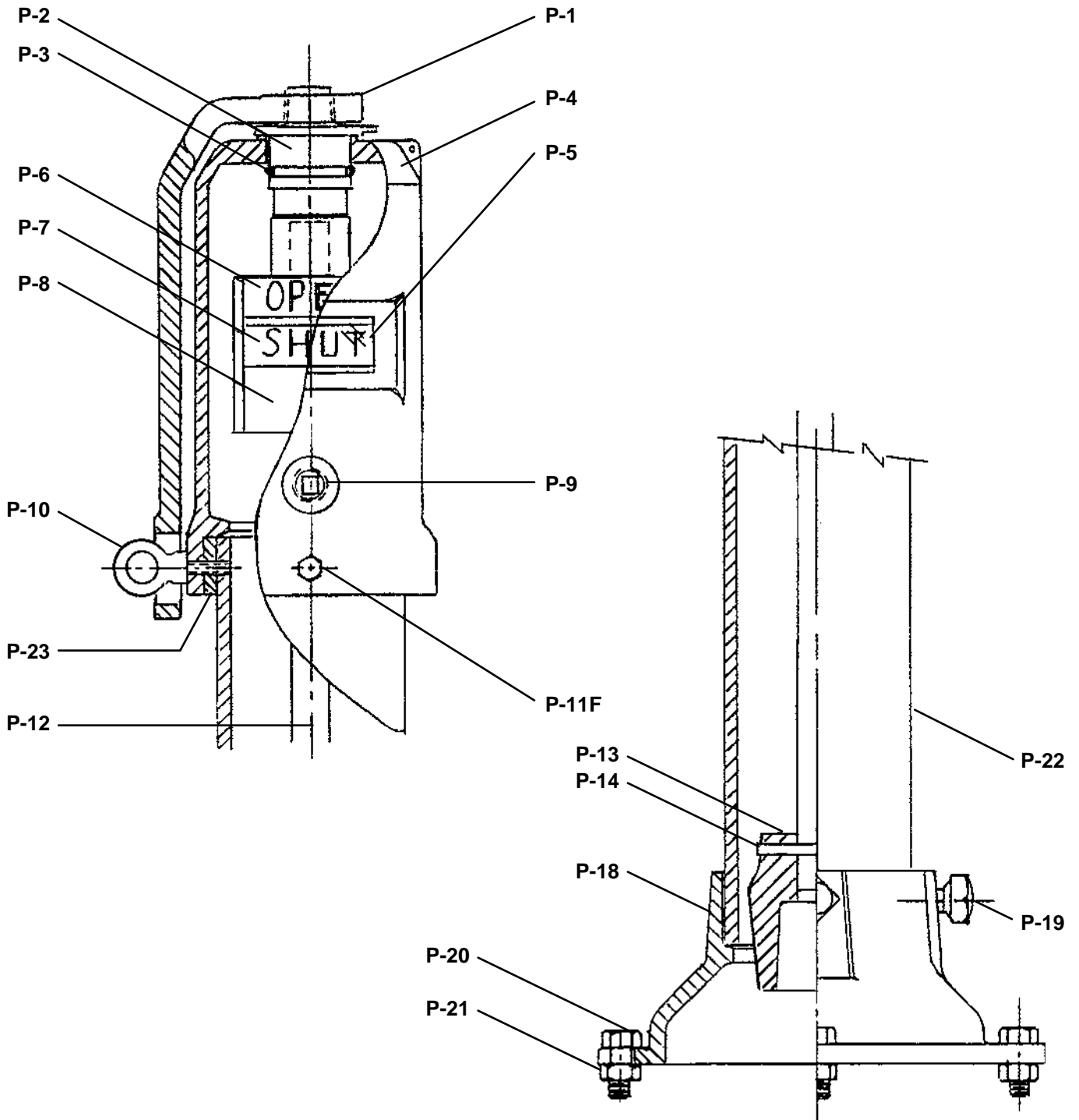

INDICATOR POST STYLE 2945 FIXED LENGTH UL/FM DIMENSIONS AND INSTRUCTIONS

KENNEDY VALVE

Available in Sizes F G H
See Page 6 for Dimensions

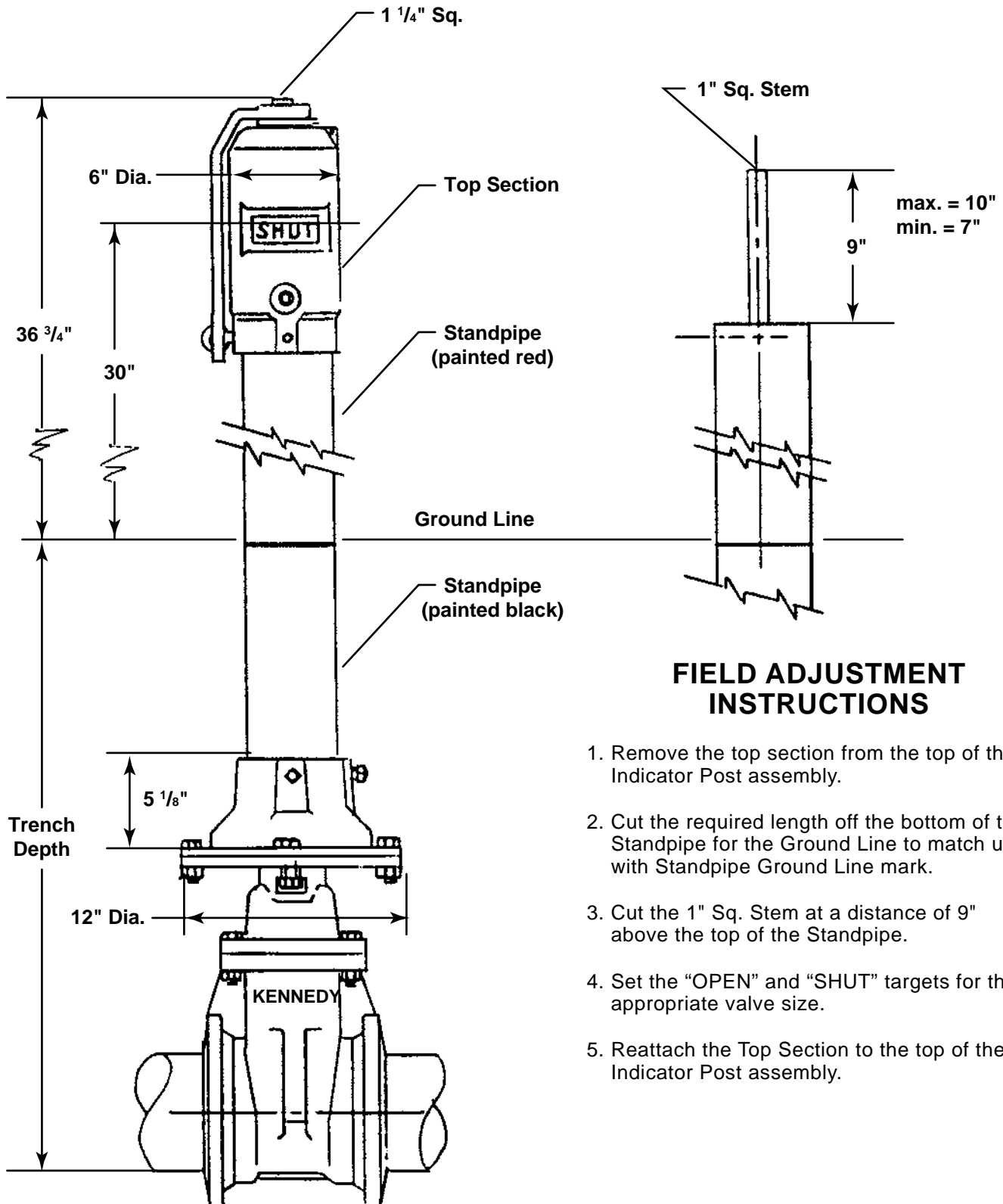

FIELD ADJUSTMENT INSTRUCTIONS

1. Remove the top section from the top of the Indicator Post assembly.
2. Cut the required length off the bottom of the Standpipe for the Ground Line to match up with Standpipe Ground Line mark.
3. Cut the 1" Sq. Stem at a distance of 9" above the top of the Standpipe.
4. Set the "OPEN" and "SHUT" targets for the appropriate valve size.
5. Reattach the Top Section to the top of the Indicator Post assembly.

INDICATOR POST STYLE 2945 A (ADJUSTABLE) AND STYLE 2945 (FIXED) - PARTS LIST

KENNEDY VALVE

| DET | QTY. | PART NO. | DESCRIPTION | MATERIAL |
|-------|------|-----------------|---|----------------------------|
| P-1 | 1 | 3361272 | Locking Wrench | Cast Iron ASTM A-126 CI.B |
| P-2 | 1 | 3024872 (4-14") | Operating Nut | Bronze ASTM B584 Alloy 864 |
| P-3 | 1 | 442639P | Retainer O-Ring #226 | Buna N |
| P-4 | 1 | 3020913 | Top Section | Cast Iron ASTM A-126 CI.B |
| P-5 | 2 | 441980P | Window Glass | Lexan - UV Stabilized |
| P-6 | 2 | 443370P | Open Target | Cast Aluminum |
| P-7 | 2 | 443371P | Shut Target | Cast Aluminum |
| P-8 | 1 | — | Target Carrier Assem. | |
| | 1 | 3005802 (4-14") | Target Carrier Nut | Bronze ASTM B584 Alloy 844 |
| | 2 | 443347P | Target Carrier Plate | 1/16" Sheet Metal |
| | 4 | 440736P | Clamp Target Retainer | 16 Ga. 302 S.S. |
| | 8 | 444171P | #10-24x1/2 " Pan Head | Stainless Steel |
| | 4 | 442411P | #10-24 Hex Nut | Zinc Plated steel |
| P-9 | 1 | 443476P | 1/2" NPT Pipe Plug | Mall. Iron |
| P-10 | 1 | 440254P | 3/8" Eyebolt #23 | Forged Steel |
| P-11A | 1 | 444303P | 3/8-16x1" Hex Capscrew (Adj. Post) | Zinc Plated Steel |
| P-11F | 2 | 444306P | 3/8-16x1 1/2" Hex Capscrew (Fixed Post) | Zinc Plated Steel |
| P-12 | 1 | ** | Stem 1" Sq. | AISI M1020 HRS |
| P-13 | 1 | 318035& | Crane Coupling | Cast Iron ASTM A-126 CI.B |
| P-14 | 1 | 442190P | Cotter Pin | Brass |
| P-15 | 2 | 444342P | 3/4" Hex Hd. Screw | Zinc Plated Steel |
| P-16 | 1 | 3004774 | Telescoping Barrel | Cast Iron ASTM A-126 CI.B |
| P-17 | 1 | ** | Lower Standpipe (Adjustable Post) | 4" D.I. CI 52 ANSI A21.51 |
| P-18 | 1 | 3180402 (3-12") | Base Flange | Cast Iron ASTM A-126 CI.B |
| P-19 | 3 | 444355P | 5/8"x1" Hex Hd. Screw | Zinc Plated Steel |
| P-20 | 4 | 444357P | 5/8"x2 1/4" Hex Capscrew | Zinc Plated steel |
| P-21 | 4 | 442484P | 5/8" Hex Nut | Zinc Plated Steel |
| P-22 | 1 | ** | Standpipe Section (Fixed Post) | 4" D.I. CI 52 ANSI A21.51 |
| P-23 | 1 | 3004762 | Spacer Sleeve (Fixed Post) | 5" D.I. CI 52 ANSI A21.51 |

**Part numbers change based on post furnished.

**INDICATOR POST STYLE 2945A & 2945
TRENCH DEPTHS FOR GATE VALVES
UL & FM APPROVED**

KENNEDY VALVE

**TELESCOPING BARREL 2945A
TRENCH DEPTH LIMITS**

| Valve Size | B Size | | C Size | | D Size | | E Size | |
|------------|--------|------|--------|------|--------|------|--------|------|
| | Min. | Max. | Min. | Max. | Min. | Max. | Min. | Max. |
| 4" | 31" | 51" | 49" | 69" | 67" | 87" | 88" | 111" |
| 6" | 35" | 55" | 53" | 73" | 71" | 91" | 92" | 115" |
| 8" | 42" | 62" | 60" | 80" | 78" | 98" | 99" | 122" |
| 10" | 45" | 65" | 63" | 83" | 81" | 101" | 102" | 125" |
| 12" | 49" | 69" | 67" | 87" | 85" | 105" | 106" | 129" |
| 14" | 58" | 78" | 76" | 96" | 94" | 114" | 115" | 138" |

**FIXED LENGTH POSTS 2945
MAXIMUM TRENCH DEPTH**

| Valve Size | F Size | G Size | H Size |
|------------|----------------------------------|----------------------------------|----------------------------------|
| 4" | 45 ¹ / ₂ " | 63 ¹ / ₂ " | 87 ¹ / ₂ " |
| 6" | 49 ¹ / ₂ " | 67 ¹ / ₂ " | 91 ¹ / ₂ " |
| 8" | 54 ¹ / ₂ " | 72 ¹ / ₂ " | 96 ¹ / ₂ " |
| 10" | 59" | 77" | 101" |
| 12" | 64" | 82" | 106" |
| 14" | 69" | 87" | 111" |

INDICATOR POST MODEL 2945A AND 2945 UL/FM INSTALLATION INSTRUCTIONS

KENNEDY VALVE

Installation - The valve should be opened to the fully open position before proceeding with the Indicator Post installation.

1. Disassembly of the Indicator Post Unit

Telescoping Barrel Units

- Remove the Top Section from the end of the barrel.
- Loosen the two screws on the barrel and slide off the top of the standpipe.

Fixed Length Units

- Remove the Top Section from the end of the standpipe.

2. Base Flange Installation:

- Attach the base flange along with the standpipe to the valve plate using the four 5/8" bolts and nuts provided.

3. Grade Line Adjustments:

Telescoping Barrel Units

- Lower the barrel over the standpipe until the grade line mark on the barrel is at ground line height and then tighten the two screws securely.

Fixed Length Units

- Cut the required length off the bottom of the standpipe so that the indicated grade line of the standpipe is at the ground line height and then secure to the base flange by tightening the two screws.

4. Extension Rod Adjustments:

Lower the stem into the barrel/standpipe, placing the crane coupling over the valve operating nut.

It is necessary that the stem engage the operating nut a minimum of 2 inches, but not more than 5 inches.

To check for correct engagement, the end of the stem should be from 7 inches to 10 inches above the top of the standpipe (Fixed Length Units) or the top of the telescoping barrel.

5. Target (Open and Shut) Adjustments

Remove the target assembly from inside the body by rotating the operating nut counterclockwise.

Loosen the target retainer screws, but do not remove them.

INDICATOR POST MODEL 2945A AND 2945 UL/FM INSTALLATION INSTRUCTIONS

KENNEDY VALVE

5. Cont'd

Open Left Valves

Move the OPEN target to the top of the plate.

Note: Position of the SHUT target can be determined by the following chart:

| Valve Size | 4" | 6" | 8" | 10" | 12" | 14" |
|----------------|-------------------|----------------------------------|-----------------------------------|----------------------------------|---------------------------------|---------------------------------|
| Gate Valve "A" | 1" | 1 ³ / ₈ " | 1 ³ / ₁₆ " | 2 ³ / ₁₆ " | 2 ⁵ / ₈ " | 3" |
| RW Valve "A" | 7/ ₈ " | 1 ⁵ / ₁₆ " | 1 ¹¹ / ₁₆ " | 2 ¹ / ₈ " | 2 ¹ / ₂ " | 2 ⁷ / ₈ " |

Position the SHUT target as indicated below and tighten the retainer screws until snug. Avoid over tightening. Repeat the procedure for the other side.

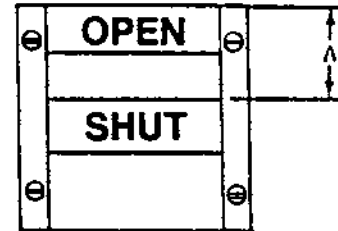
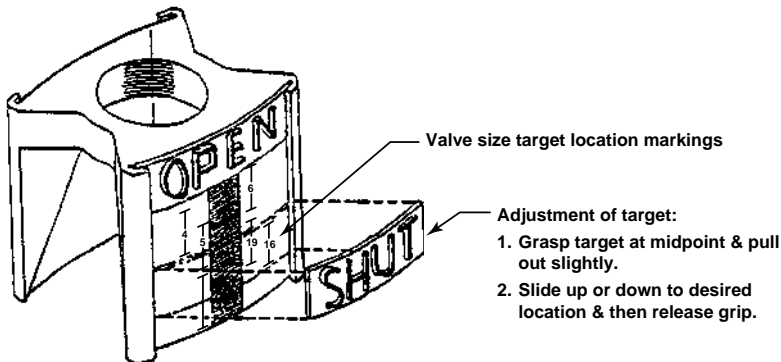

Open Right Valves

The procedure is similar as for open left, but with two differences:

A: The open target is placed **below** the shut target.

B: The open target is placed at the very **bottom** of the plate.

The position of the shut target above the open target is then determined and set as described above.

Maintenance

1. Lubrication

Oil upper bearing at least once per year, adding several drops of oil in the hole located on the top of the main stem flange.

Access to lubrication hole is gained by raising the locking wrench off the main stem nut.

2. Operation

The target mechanism will travel off the threads of the operating nut in both directions should the targets or target mechanism be positioned incorrectly. Should this happen, readjust targets. If the target mechanism falls from the operating nut, it will be stopped a short distance below the window.

2945 (A) Vertical Indicator Post - Changing the Lower Standpipe

1. Loosen (2) 3/4" - UNC Bolts (Items P-15) that retain the Telescoping Barrel (Item P-16) to the lower Standpipe (Item P-17)
2. Working in a safe manner lift off the entire top assembly (Items P-1 through P-16) from the Telescoping Barrel and Base Flange
3. Remove the Stem (Item P-12) and Crane Coupling (Item P-13) sub-assembly
4. Loosen the 3/4" -UNC Bolts (19) that retain the Lower Standpipe to the Base Flange
5. Remove the existing Lower Standpipe and set the new one into the socket in the Base Flange.
6. Securely tighten the bolts that were loosened in Step 4 (50 to 100 ft.-lb)
7. Working safely, slide the entire top assembly over the new Lower Standpipe
8. Tighten the (2) 3/4" - UNC Bolts that retain the Telescoping Barrel to the Lower Standpipe (Item P-15) - Tighten them securely enough to safely maneuver the Post in the field
9. Remove the Wrench (Item P-1), the 3/8" - UNC Bolt (Item 11A) and the Eyebolt (Item P-10)
10. Lift the assembly of the Top Section (Item P-4), Operating Nut (Item P-2), Target Carrier Assembly Items P-6 through P-8), etc. from the Telescoping Barrel.
11. If a longer Lower Standpipe has been installed it will be necessary to procure a longer Stem. Slip the Crane Coupling (Item P-13) over one end of the new Stem and cross drill a new, cotter pin hole through the new Stem
12. If the Lower Standpipe just installed is shorter than the one it replaced the Stem will have to be cut
13. Bolt the Base Flange of the sub-assembly that includes the Base Flange, Lower Standpipe and Telescoping Barrel to the flange of the valve, using the 3/4" - UNC Bolts & Nuts provided by Kennedy Valve
14. Place the square socket in the Crane Coupling on the Stem & Coupling sub-assembly over the 2" Square Nut at the top of the stem of the valve
15. See page F-4 of the Kennedy Valve Product Catalog and follow the directions.

NOTE: Kennedy Valve does offer for sale Couplings to extend Stems

INSTRUCTIONS FOR EXTENDING A 2945A POST

Loosen the two 3/4" screws on top pipe section (near grade line at bottom of pipe). Pull apart the upper section from the lower pipe section. Place new extension coupling with new extension pipe over the existing lower pipe section. Tighten screws provided on the extension pipe and lower pipe (3/4" X 1" square head screw). Take existing stem and place the new extension stem with coupling on top of original stem. Drill through stem and coupling (pilot holes provided on one side) then pin together with pins provided (1/4" X 3" br. cotter keys). Place stem down the inside of new extension and lower pipe assembly aligning it on the 2" square nut on valve. At this time, remove top section (with operating nut assembly) from off the top of indicator post standpipe (two bolts). Place complete upper section over top of stem and align with the new extension pipe. Push together, adjust to desired height, and retighten the two 3/4" screws in top pipe section. Stem should be cut 7" - 10" above the pipe. Adjust open/shut plates per instructions and replace top section with stem nut (can also be extended at bottom end).

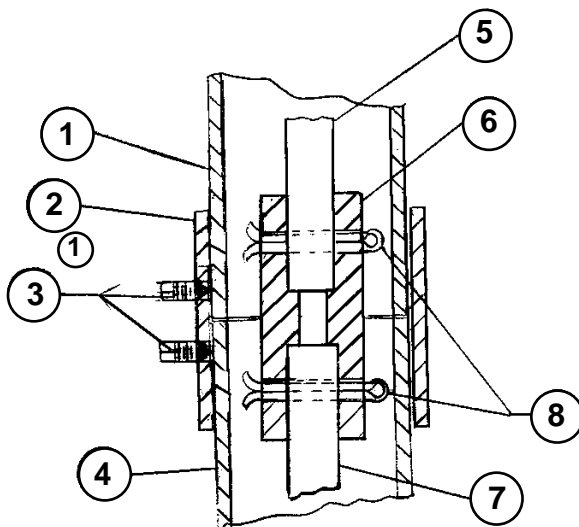

| NO. | DESCRIPTION |
|-----|--------------------------|
| 1 | Ductile Pipe (as reqd) |
| 2 | Extender Coupling |
| 3 | Set Screw 3/4 UNC X 1"lg |
| 4 | Lower |
| 5 | Extension Stem |
| 6 | Ext. Stem Coupling |
| 7 | Existing Stem |
| 8 | Cotter Pin |

641 Wall Post

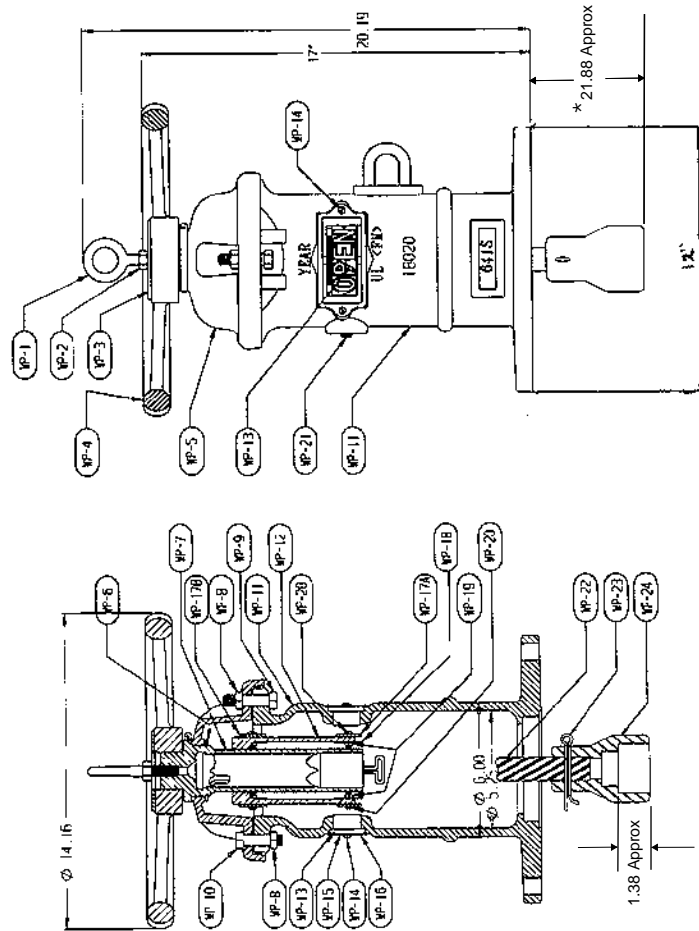

NOTE. 9 TO 39+ TURNS

* Standard over-all stem length = 34.63

Fig. 551-Angle Wall Post Kit, use with 641-13 wall post (Style "A" includes 2 – 18" stems)
 (Style "B" includes 2 – 24" stems)

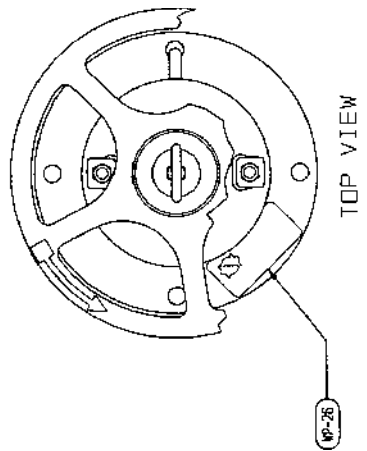
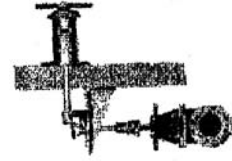

Fig. 551
 Angle
 Wall
 Post Kit



| NO. | ITEM | QTY | MATL | SPEC | REMARKS | PART NO. |
|-------------|---------------------------|-------|---------|----------|-------------------|----------|
| WP-1 | Eye Bolt 1/2-UNC 2" LG | 1 | Stl | | 1/2-UNC | 440253P |
| WP-2 | Nut 1/2-UNC Plated | 1 | Stl | | Eye Bolt | 477495P |
| WP-3 | Washer 5/8 0 Plated | 1 | Stl | | | 445834P |
| WP-4 | Handwheel-14" Dia. | 1 | Cl | | | 3360152 |
| WP-5 | Cover | 1 | Cl | A126-B | Zinc Plate | 3180283 |
| WP-6 | Ret. Ring #5100-225 | 1 | Stl | | | 443599P |
| WP-7 | Oper. Stem Nut | 1 | BR | AWWA 'A' | | 3180165 |
| WP-8 | Nuts 1/2-UNC Plated | 2 | RP Stl | | Heavy Hex | 442482P |
| WP-9 | Bolt 1/2-UNC x 2" | 1 | RP Stl | A304 | Hex Drilled-1 End | 444419P |
| WP-10 | Bolt 1/2-UNC x 1.75" | 1 | RP Stl | A304 | Hex | 444348P |
| WP-11 | Top Sect. | 1 | Cl | A126-B | | 3180204 |
| WP-12 | Target Nut | 1 | Br | AWWA 'A' | | 3180172 |
| WP-13 | Windows – Flat | 2 | Plastic | | | 441982P |
| WP-14 | Screws 1/40 3/4 Self Tap | 4 | | | | 444435P |
| WP-15 | Ferrule | 2 | Stl | | | 441587P |
| WP-17A | Target Plate (Open) | 2 | Alum | | | 443348P |
| WP-17B | Target Plate (Shut) | 2 | Alum | | | 443350P |
| WP-18 | Clamps – Plated | 4 | Stl | | | 440734P |
| WP-19 | Nuts 1/4-20 UNC | 8 | Stl | | Sq. Hd. | 442576P |
| WP-20 | Mach Screw 1/4-20 x 7/8LG | 8 | Br | | Rd. Hd. | 444432P |
| WP-21 | Pipe Plug-1/2 NPT | 1 | Iron | | Socket Hd. | 443476P |
| WP-22/23/24 | S/A Stem | 1 Ea. | | | | 2180912 |
| WP-22 | Stem – (Std. Lg - 32.5") | 1 | Stl | | 1" Square | 445312L |
| WP-23 | Cotter Pin 1/4 x 3 Lg | 1 | Br | | | 442190P |
| WP-24 | Crane Coupling | 1 | Cl | | | 318035& |
| WP-25 | Adjustment Card | 1 | | | Not Shown | 440443P |
| WP-26 | Marking Tag | 1 | Mylar | | UL Rated Matl | |

| CAST TOLERANCES | NO | DATE | ECN | REVISION |
|-------------------|----|------|-----|----------|
| 0" to 3" ± .03" | | | | |
| 3" to 6" ± .04" | | | | |
| 6" to 9" ± .05" | | | | |
| 9" to 12" ± .06" | | | | |
| 12" to 18" ± .08" | | | | |
| 18" to 24" ± .10" | | | | |
| 24" to 30" ± .11" | | | | |
| 30" to 36" ± .12" | | | | |
| ANGLES ± .50 DEG. | | | | |

| | |
|---------------------------------------|-------------------------------------|
| Material: xxx | KENNEDY VALVE ELMIRA, N.Y. 14801 |
| Material Weight: xxx | |
| WALL TYPE INDICATOR POST ILLUSTRATION | |
| PART NO. D XXXXX | DWG. NO. 81286 |
| Drawn by: BES | Scale 1/2 |
| Issued: xxx | REVISION 01 |

FLANGED BASE POST INDICATOR

KENNEDY VALVE

The Kennedy Flanged Base Indicator Post, Figure 641-14, is specially designed to be mounted on a vault/ pit cover. This non-adjustable post can be supplied with couplings for non-rising stem valves.

PARTS LIST

| NO. | ITEM | MATL | ASTM |
|-----|----------------------|--------|-------|
| *1 | WELDLESS EYE BOLT | STL | |
| — | | | |
| *3 | WASHER-PLATED | STL | A108 |
| *4 | HANDWHEEL-14" DIA | CI | A126B |
| 5 | COVER | CI | A126B |
| 6 | SNAP RINGS #5100-225 | | |
| 7 | STEM NUT | BR | B-62 |
| 8 | NUTS 1/2-UNC PLATED | AP STL | |
| 9 | BOLT 1/2-UNC X 2" | AP STL | A304B |
| 10 | BOLT 1/2-UNC X 1.75" | AP STL | A304B |
| 11 | TOP SECTION | CI | A126B |
| 12 | TARGET NUT | BR | B-62 |
| 13 | WINDOWS | PLAST | |
| 14 | SCREWS-SELF TAP | STL | |
| 15 | FERRULE | STL | |
| 16a | TARGET PLATE (OPEN) | ALUM | |
| 16b | TARGET PLATE (SHUT) | ALUM | |
| 17 | CLAMPS-PLATED | STL | |
| 18 | NUTS-SQUARE | STL | |
| 19 | MACH SCREW-AD HEAD | BR | |
| 20 | PIPE PLUG-1/2 NPT | CI | |
| 21 | 4 in. D.I. PIPE | DI | |
| 22 | 4 in. FLOOR FLANGE | CI | A126B |
| 23 | STEM 87" STANDARD | STL | |
| 24 | WRENCH | MI | A47 |
| 25 | CRANE COUPLING | CI | A126B |
| 26 | COTTER PIN | BR | B-16 |

*DENOTES OPTIONAL HANDWHEEL PARTS.

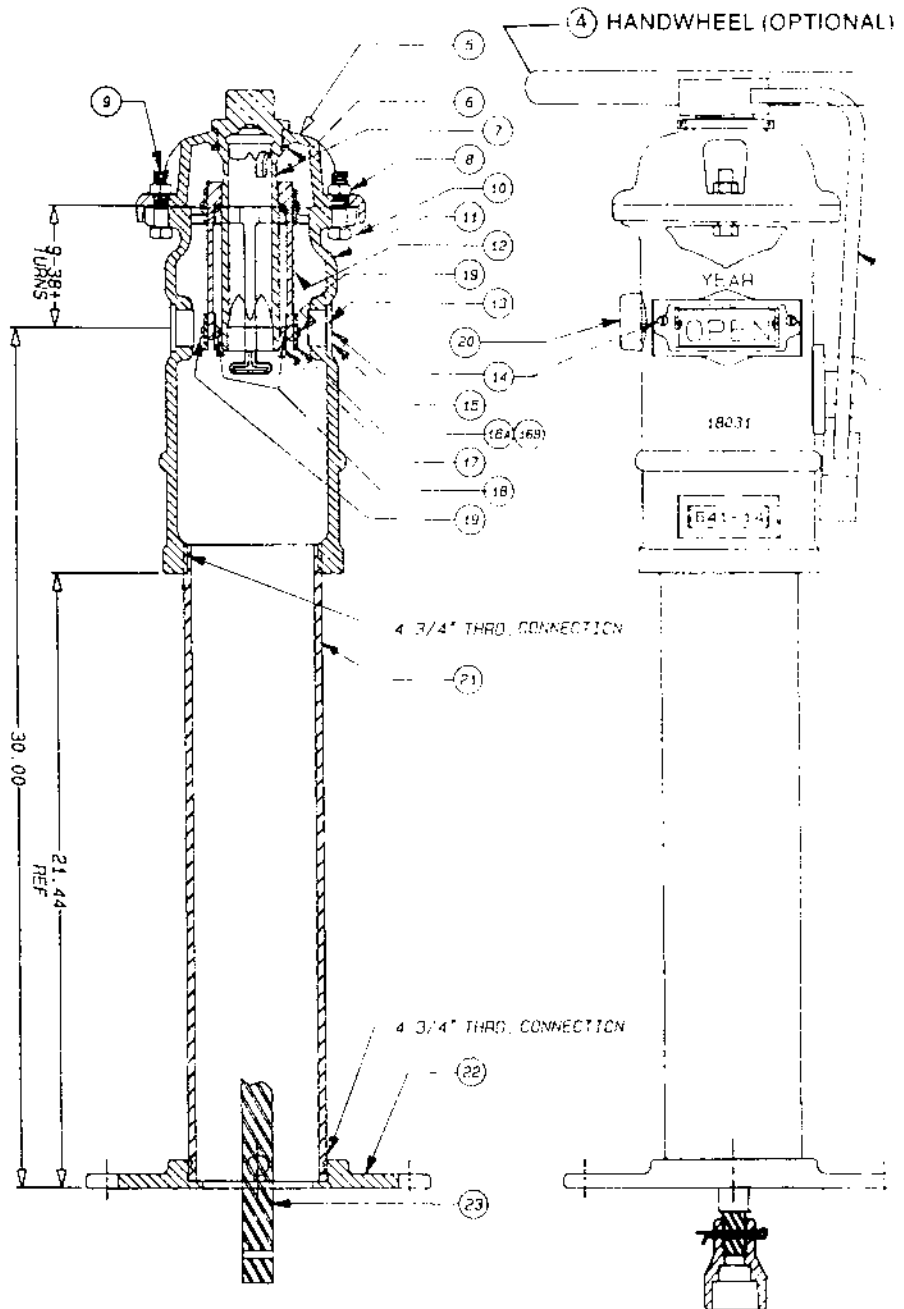

FIGURE 641-14

NON-RISING
STEM APPLICATION