

Telescoping Post Indicator

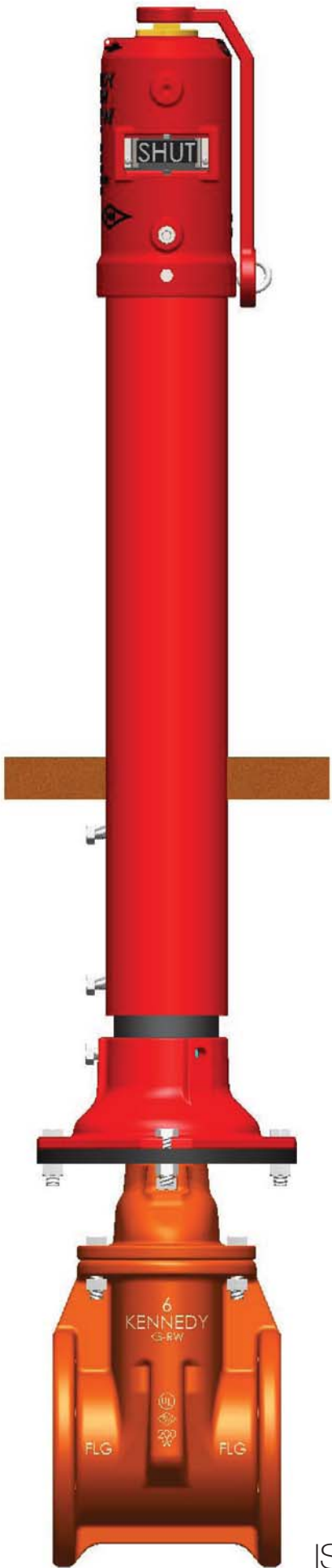

Wall Post



KENNEDY
VALVE

ISO 9000 ISO 14001

Telescoping Post Indicator

2945 A

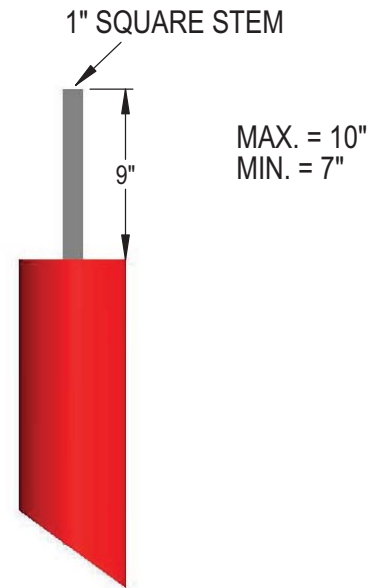
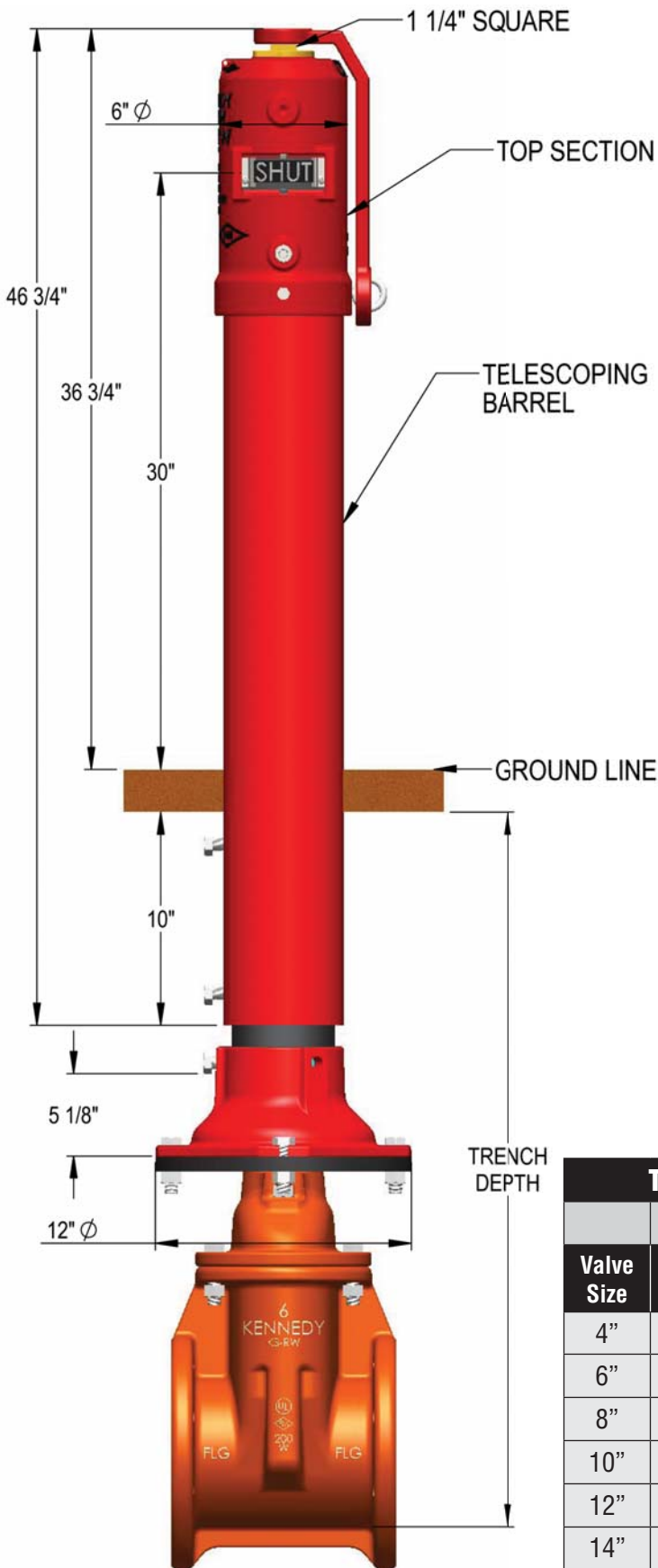

FIELD ADJUSTMENT INSTRUCTIONS

1. Remove the top section from the Indicator Post assembly.
2. Loosen the telescoping barrel screw and adjust barrel to the ground level.
3. Cut the 1" square stem at a distance of 9" above the top of the barrel end.
4. Set the "OPEN" and "SHUT" targets for the appropriate valve size.
5. Reattach the top section to the top of the Indicator Post assembly.

TELESCOPING BARREL 2945A TRENCH DEPTH LIMITS

Valve Size	B SIZE		C SIZE		D SIZE		E SIZE	
	Min.	Max.	Min.	Max.	Min.	Max.	Min.	Max.
4"	31"	51"	49"	69"	67"	87"	88"	111"
6"	35"	55"	53"	73"	71"	91"	92"	115"
8"	42"	62"	60"	80"	78"	98"	99"	122"
10"	45"	65"	63"	83"	81"	101"	102"	125"
12"	49"	69"	67"	87"	85"	105"	106"	129"
14"	58"	78"	76"	96"	94"	114"	115"	138"

Indicator Post Parts List

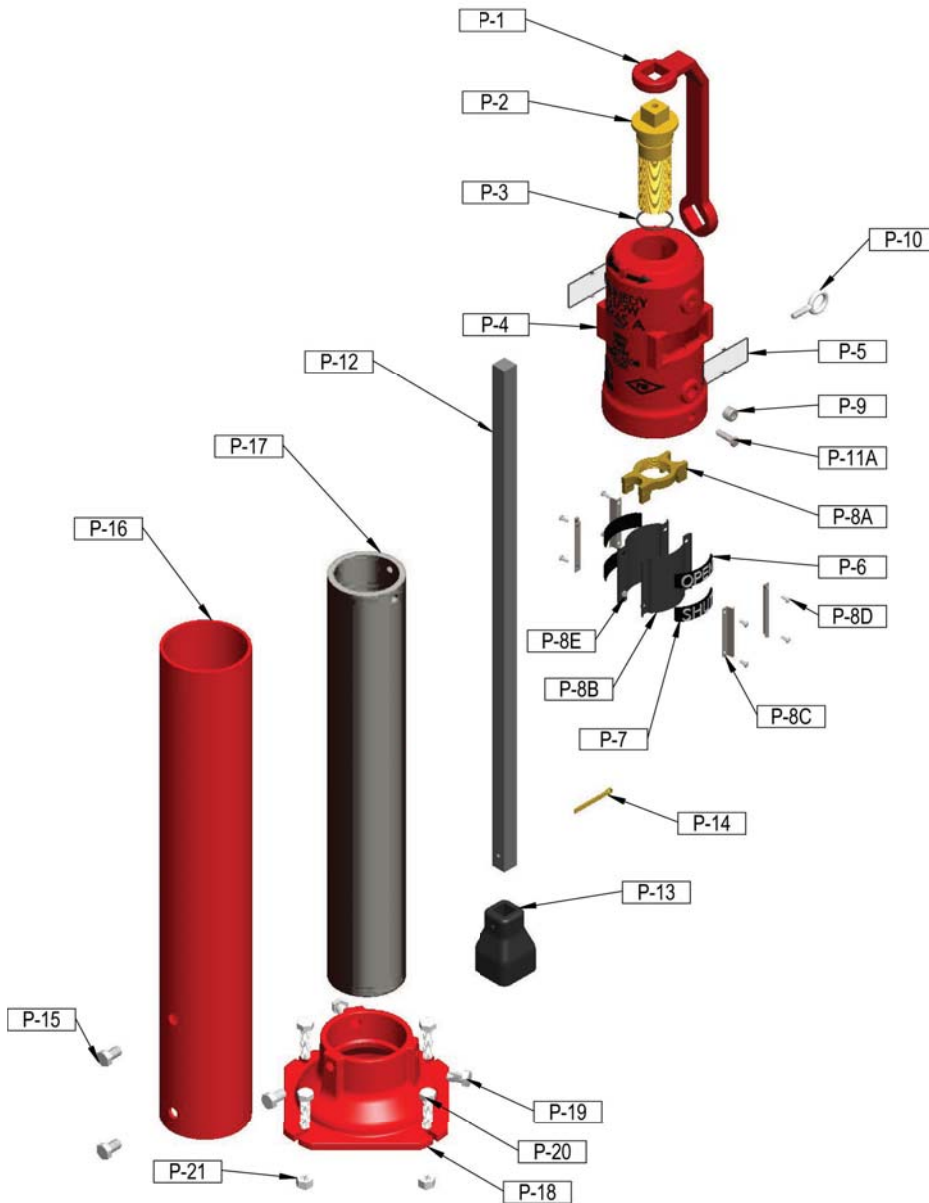

PARTS LIST				
DET	QTY	PART NO.	DESCRIPTION	MATERIAL
P-1	1	3361270	LOCKING WRENCH	CAST IRON ASTM A126 CLASS B
P-2	1	3024872 (4-14")	OPERATING NUT	BRONZE ASTM B584 ALLOY 864
P-3	1	442639P	RETAINER O-RING 226	BUNA N
P-4	1	3020912	TOP SECTION	CAST IRON ASTM A126 CLASS B
P-5	2	441980P	WINDOW GLASS	LEXAN-UV STABILIZED
P-6	2	443370P	OPEN TARGET	CAST ALUMINUM
P-7	2	443371P	SHUT TARGET	CAST ALUMINUM
P-8	1	-	TARGET CARRIER ASSEMBLY	
P-8A	1	3005802 (4-12")	TARGET CARRIER NUT	BRONZE ASTM B584 ALLOY 864
P-8B	2	443347P	TARGET CARRIER PLATE	1/16" SHEET METAL
P-8C	4	440736P	CLAMP TARGET RETAINER	16. GA 302 SS
P-8D	8	444171P	#10-24X1/2" PAN HEAD	ZINC PLATED STEEL
P-8E	4	442411P	#10-24 HEX NUT	ZINC PLATED STEEL
P-9	1	443476P	1/2" NPT PIPE PLUG	MALL. IRON
P-10	1	440254P	3/8" EYEBOLT #23	FORGED STEEL
P-11A	1	444303P	3/8-16X1" HEX CAPSCREW (ADJ. POST)	ZINC PLATED STEEL
P-12	1	**	STEM 1" SQUARE	AISI M1020 HRS
P-13	1	318035&	CRANE COUPLING	CAST IRON ASTM A126 CLASS B
P-14	1	442190P	COTTER PIN	BRASS
P-15	2	444342P	3/4" HEX HEAD SCREW	ZINC PLATED STEEL
P-16	1	3004774	TELESCOPING BARREL	5" D.I. Class 52 ANSI A21.51
P-17	1	**	LOWER STANDPIPE (ADJ. POST)	4" DI Class 52 ANSI A21.51
P-18	1	3180402 (3-12")	BASE FLANGE	CAST IRON ASTM A126 CLASS B
P-19	3	444355P	5/8"x1" HEX HEAD SCREW	ZINC PLATED STEEL
P-20	4	444357P	5/8"x2 1/4" HEX CAPSCREW	ZINC PLATED STEEL
P-21	4	442484P	5/8" HEX NUT	ZINC PLATED STEEL

INDICATOR POST MODEL 2945A AND 2945 UL/FM INSTALLATION INSTRUCTIONS

KENNEDY VALVE

Installation - The valve should be opened to the fully open position before proceeding with the Indicator Post installation.

1. Disassembly of the Indicator Post Unit

Telescoping Barrel Units

- Remove the Top Section from the end of the barrel.
- Loosen the two screws on the barrel and slide off the top of the standpipe.

Fixed Length Units

- Remove the Top Section from the end of the standpipe.

2. Base Flange Installation:

- Attach the base flange along with the standpipe to the valve plate using the four 5/8" bolts and nuts provided.

3. Grade Line Adjustments:

Telescoping Barrel Units

- Lower the barrel over the standpipe until the grade line mark on the barrel is at ground line height and then tighten the two screws securely.

Fixed Length Units

- Cut the required length off the bottom of the standpipe so that the indicated grade line of the standpipe is at the ground line height and then secure to the base flange by tightening the two screws.

4. Extension Rod Adjustments:

Lower the stem into the barrel/standpipe, placing the crane coupling over the valve operating nut.

It is necessary that the stem engage the operating nut a minimum of 2 inches, but not more than 5 inches.

To check for correct engagement, the end of the stem should be from 7 inches to 10 inches above the top of the standpipe (Fixed Length Units) or the top of the telescoping barrel.

5. Target (Open and Shut) Adjustments

Remove the target assembly from inside the body by rotating the operating nut counterclockwise.

Loosen the target retainer screws, but do not remove them.

INDICATOR POST MODEL 2945A AND 2945 UL/FM INSTALLATION INSTRUCTIONS

KENNEDY VALVE

5. Cont'd

Open Left Valves

Move the OPEN target to the top of the plate.

Note: Position of the SHUT target can be determined by the following chart:

Valve Size	4"	6"	8"	10"	12"	14"
Gate Valve "A"	1"	1 ³ / ₈ "	1 ¹³ / ₁₆ "	2 ³ / ₁₆ "	2 ⁵ / ₈ "	3"
RW Valve "A"	7/ ₈ "	1 ⁵ / ₁₆ "	1 ¹¹ / ₁₆ "	2 ¹ / ₈ "	2 ¹ / ₂ "	See Note (1)

Position the SHUT target as indicated below and tighten the retainer screws until snug. Avoid over tightening. Repeat the procedure for the other side.

Note (1): Resilient Seat Gate Valves 14" and larger, require special target mechanism threads. Contact Kennedy Valve Engineering

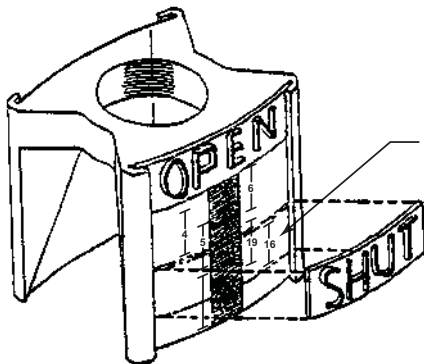

- Adjustment of target:
1. Grasp target at midpoint & pull out slightly.
 2. Slide up or down to desired location & then release grip.

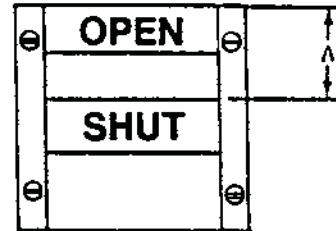

Open Right Valves

The procedure is similar as for open left, but with two differences:

A: The open target is placed **below** the shut target.

B: The open target is placed at the very **bottom** of the plate.

The position of the shut target above the open target is then determined and set as described above.

Maintenance

1. Lubrication

Lubricate upper bearing area at least once per year, by applying several drops of light machine oil or food grade grease to the areas where the Operating Nut (P-2) contacts the Top Section (P-4).

Access to this area is gained by removing the Locking Wrench (P-1) and lifting upward on the Operating Nut (P-2).

2. Operation

The target mechanism will travel off the threads of the operating nut in both directions should the targets or target mechanism be positioned incorrectly. Should this happen, readjust targets. If the target mechanism falls from the operating nut, it will be stopped a short distance below the window.

2945 (A) Vertical Indicator Post - Changing the Lower Standpipe

1. Loosen (2) 3/4" - UNC Bolts (Items P-15) that retain the Telescoping Barrel (Item P-16) to the lower Standpipe (Item P-17)
2. Working in a safe manner lift off the entire top assembly (Items P-1 through P-16) from the Telescoping Barrel and Base Flange
3. Remove the Stem (Item P-12) and Crane Coupling (Item P-13) sub-assembly
4. Loosen the 3/4" -UNC Bolts (19) that retain the Lower Standpipe to the Base Flange
5. Remove the existing Lower Standpipe and set the new one into the socket in the Base Flange.
6. Securely tighten the bolts that were loosened in Step 4 (50 to 100 ft.-lb)
7. Working safely, slide the entire top assembly over the new Lower Standpipe
8. Tighten the (2) 3/4" - UNC Bolts that retain the Telescoping Barrel to the Lower Standpipe (Item P-15) - Tighten them securely enough to safely maneuver the Post in the field
9. Remove the Wrench (Item P-1), the 3/8" - UNC Bolt (Item 11A) and the Eyebolt (Item P-10)
10. Lift the assembly of the Top Section (Item P-4), Operating Nut (Item P-2), Target Carrier Assembly Items P-6 through P-8), etc. from the Telescoping Barrel.
11. If a longer Lower Standpipe has been installed it will be necessary to procure a longer Stem. Slip the Crane Coupling (Item P-13) over one end of the new Stem and cross drill a new, cotter pin hole through the new Stem
12. If the Lower Standpipe just installed is shorter than the one it replaced the Stem will have to be cut
13. Bolt the Base Flange of the sub-assembly that includes the Base Flange, Lower Standpipe and Telescoping Barrel to the flange of the valve, using the 3/4" - UNC Bolts & Nuts provided by Kennedy Valve
14. Place the square socket in the Crane Coupling on the Stem & Coupling sub-assembly over the 2" Square Nut at the top of the stem of the valve
15. See page 17-4 of the Kennedy Valve Product Catalog and follow the directions.

NOTE: Kennedy Valve does offer for sale Couplings to extend Stems

INSTRUCTIONS FOR EXTENDING A 2945A POST

Loosen the two 3/4" screws on top pipe section (near grade line at bottom of pipe). Pull apart the upper section from the lower pipe section. Place new extension coupling with new extension pipe over the existing lower pipe section. Tighten screws provided on the extension pipe and lower pipe (3/4" X 1" square head screw). Take existing stem and place the new extension stem with coupling on top of original stem. Drill through stem and coupling (pilot holes provided on one side) then pin together with pins provided (1/4" X 3" br. cotter keys). Place stem down the inside of new extension and lower pipe assembly aligning it on the 2" square nut on valve. At this time, remove top section (with operating nut assembly) from off the top of indicator post standpipe (two bolts). Place complete upper section over top of stem and align with the new extension pipe. Push together, adjust to desired height, and retighten the two 3/4" screws in top pipe section. Stem should be cut 7" - 10" above the pipe. Adjust open/shut plates per instructions and replace top section with stem nut (can also be extended at bottom end).

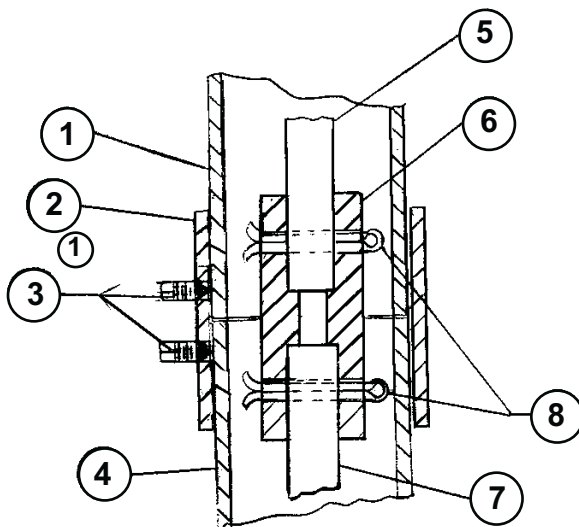

NO.	DESCRIPTION
1	Ductile Pipe (as reqd)
2	Extender Coupling
3	Set Screw 3/4 UNCX1"lg
4	Lower
5	Extension Stem
6	Ext. Stem Coupling
7	Existing Stem
8	Cotter Pin

Wall Post

2945 W

Angle Bracket Kit for Wall Post

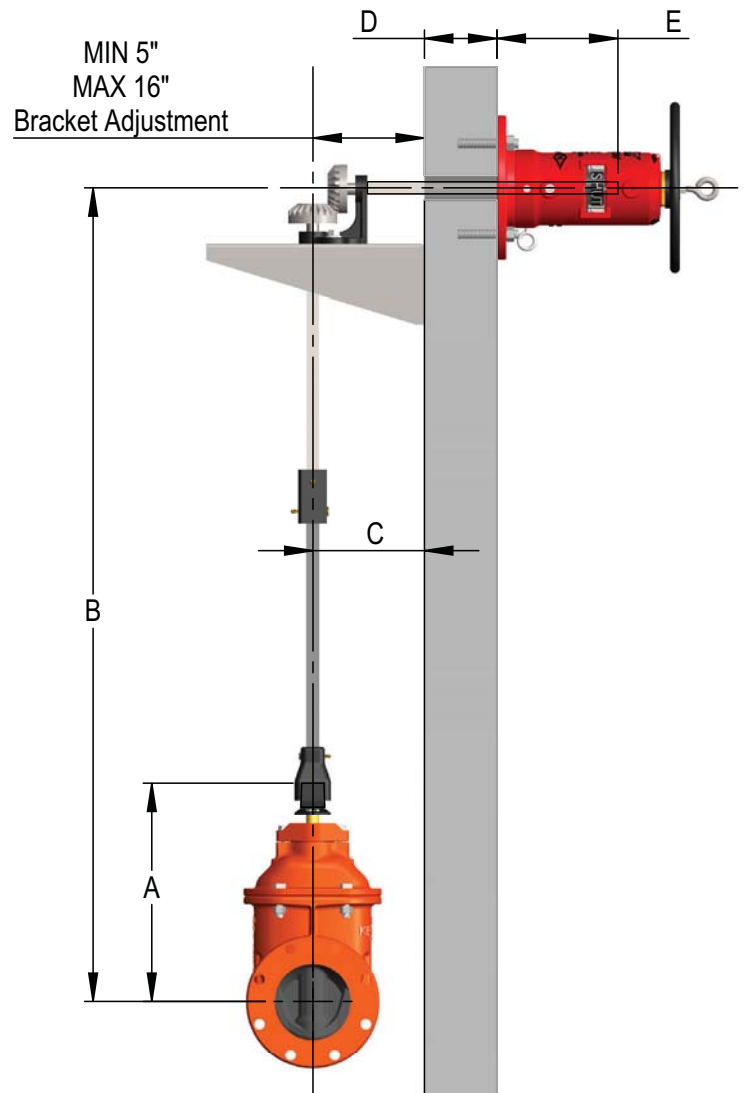

SIZE (inches)		4	6	8	10	12
Centerline to Coupling	A	14.75	19	22.50	26.50	30
Minimum Dimension – Centerline of valve to Centerline of Indicator Post	B	25	29	32.50	36	40.375
Minimum Centerline of Valve to Wall	C	7	7	8.375	9.375	10.50
Wall Thickness (Reference)	D	6	6	6	6	6
Minimum Stem Length from Wall	E	10	10	10	10	10
Stem Length		24	24	24	36	36

NOTES

Angle Bracket kit includes two equal length stems. Available kit lengths are 18", 24", 36" and 52". Stems are to be cut to length in field if valves don't conform to table.



KENNEDY VALVE a division of McWane



MADE IN THE USA

1021 East Water Street • P.O. Box 931 • Elmira, New York 14901 • ph: 607.734.2211 • fax: 800.952.4771

Updated 4/4/2014

Wall Post Parts List

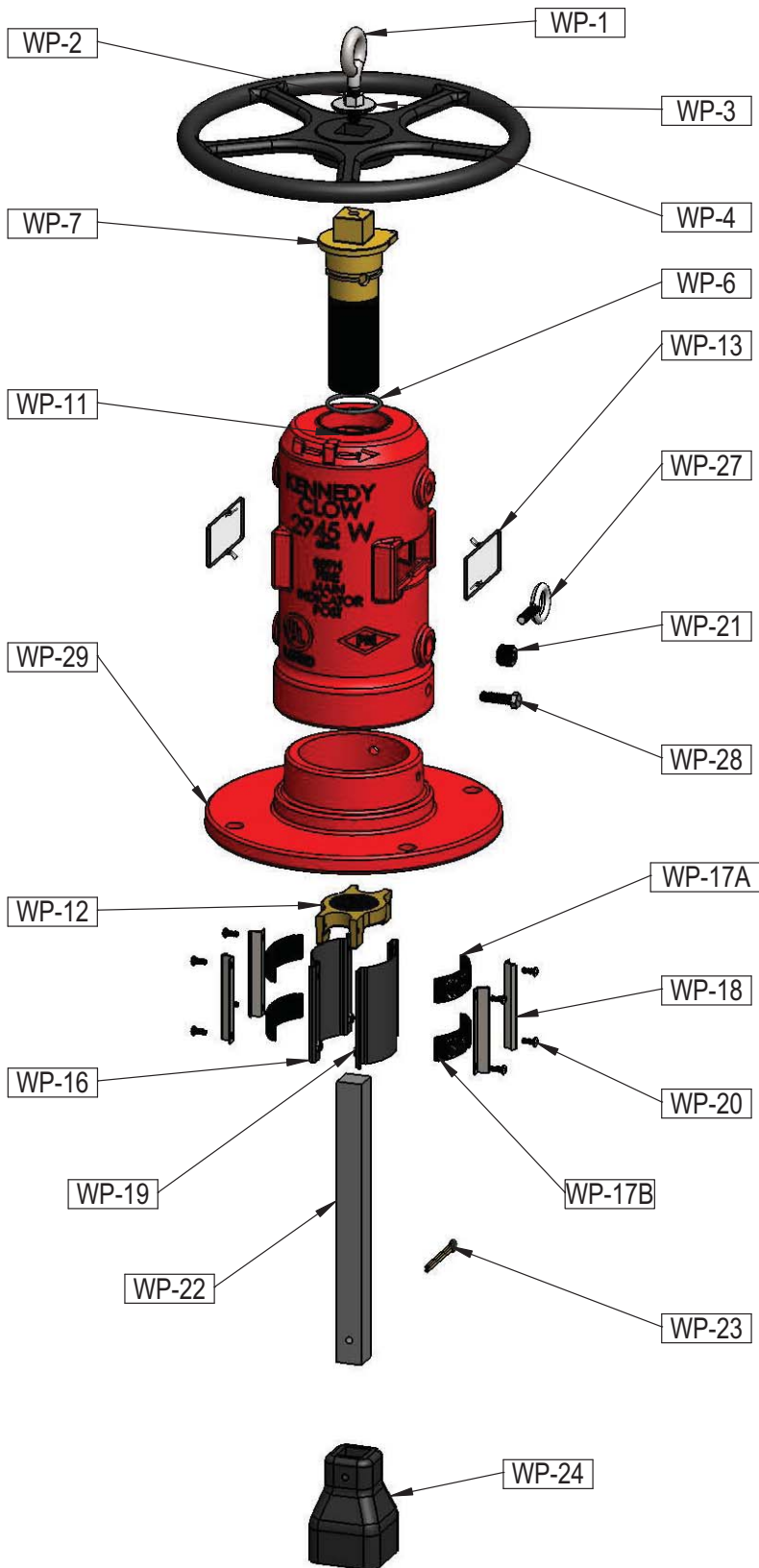

PARTS LIST				
NO.	ITEM	QTY	MATERIAL	PART NO.
WP-1	EYEBOLT 1/2-UNC 2" LONG	1	STEEL	440253P
WP-2	NUT 1/2-UNC PLATED	1	STEEL	477495P
WP-3	WASHER 5/8 PLATED	1	STEEL	445834P
WP-4	HANDWHEEL 14" DIA.	1	DUCTILE IRON	436015P O/L 436032P O/R
WP-6	RETAINER O-RING #226	1	BUNA	442639P
WP-7	OPERATING STEM NUT	1	BRONZE ASTM B584 ALLOY 864	3024872
WP-11	TOP SECTION	1	CAST IRON ASTM A126 CLASS B	3020942
WP-12	TARGET CARRIER NUT	1	BRONZE ASTM B584 ALLOY 864	3005802
WP-13	WINDOW	2	LEXAN-UV STABI- LIZED	441980P
WP-16	TARGET CARRIER PLATE	2	1/16" SHEET METAL	443347P
WP-17A	OPEN TARGET PLATE	2	CAST ALUMINUM	443370P
WP-17B	SHUT TARGET PLATE	2	CAST ALUMINUM	443371P
WP-18	CLAMP TARGET RETAINER	4	16. GA 302 SS	440736P
WP-19	#10-24 HEX NUT	4	ZINC PLATED	442411P
WP-20	#10-24X1/2" PAN HEAD SCREW	8	ZINC PLATED	444171P
WP-21	PIPE PLUG-1/2" NPT	1	STEEL	443476P
WP-22	STEM 1" SQUARE	1	AISI M1020 HRS	445312L
WP-23	COTTER PIN	1	BRASS	442190P
WP-24	CRANE COUPLING	1	CAST IRON ASTM A126 CLASS B	318035&
WP-27	3/8" EYEBOLT #23	1	FORGED STEEL	440254P
WP-28	3/8-16X1" HEX CAPSCREW	1	ZINC PLATED STEEL	444306P
WP-29	BASE FLANGE	1	CAST IRON ASTM A126 CLASS B	3180252

Pit Post

2945 P

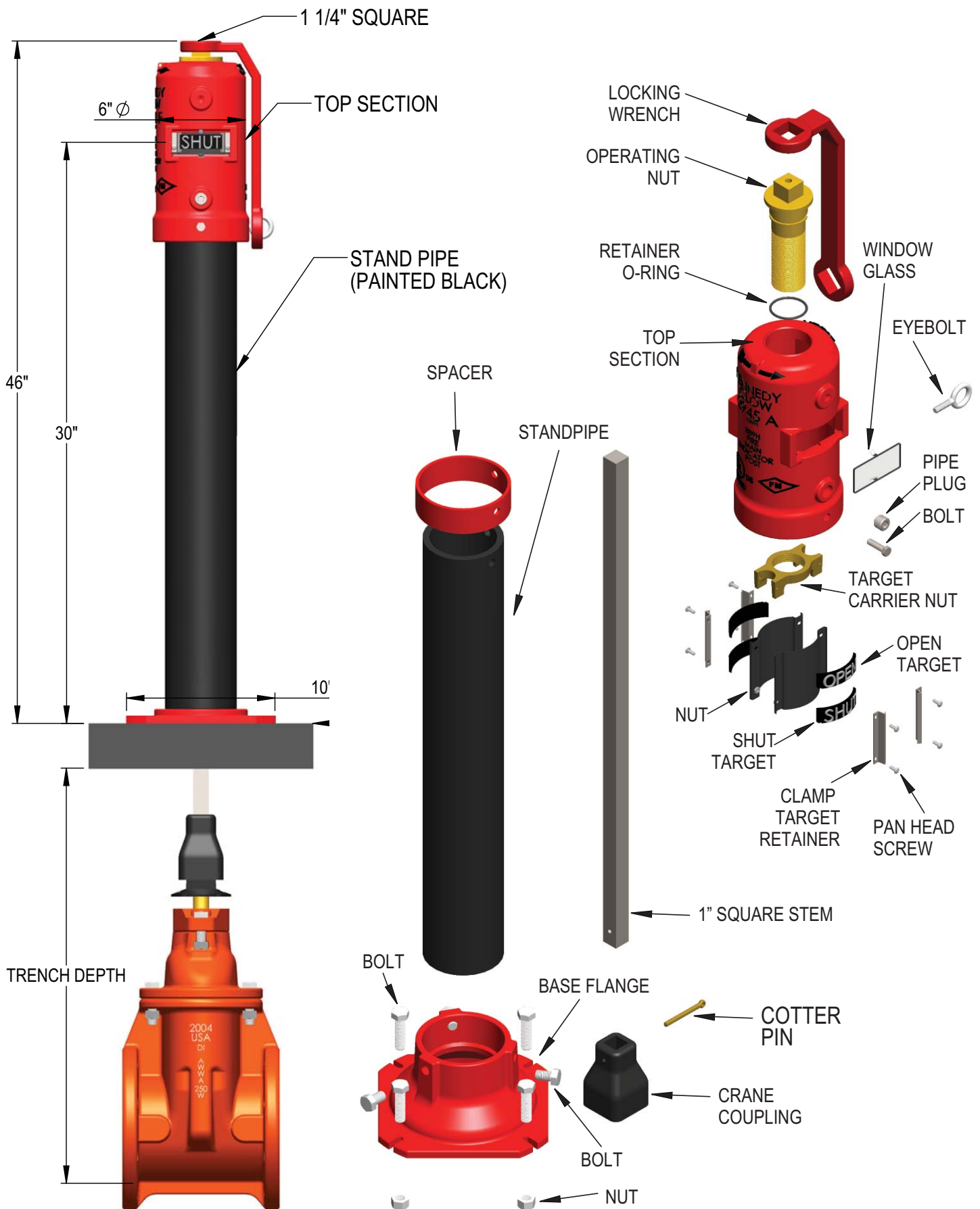

Updated 4/4/2014

*SEE PAGE 3 (INDICATOR POST PARTS) FOR REPLACEMENT PARTS



Kennedy Valve

A DIVISION OF McWANE, INC.

www.kennedyvalve.com

2009

1021 E. Water Street • Elmira, New York 14901

P.O. Box 981

PHONE: (607) 734-2211 • FAX: 1-800-952-4771

[Updated 4/4/2014](#)