

KVOS-2
KSRW/KSRWHP

INSTALLATION INSTRUCTIONS
FOR INDOOR & OUTDOOR USE

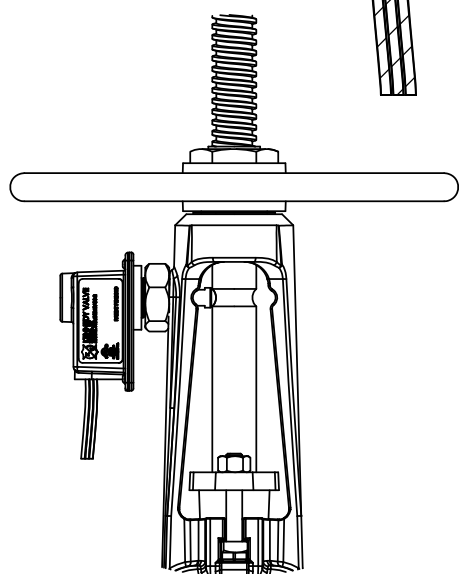
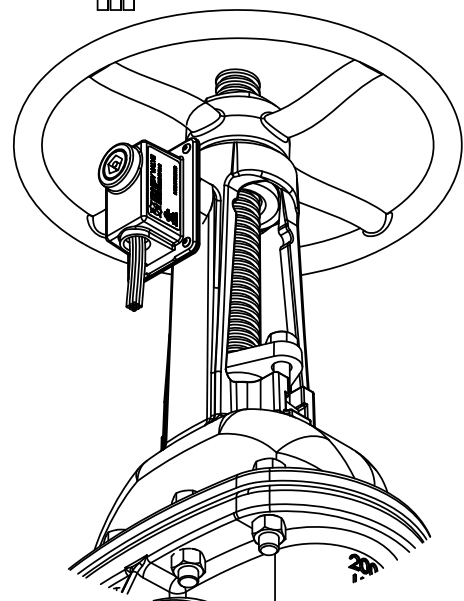
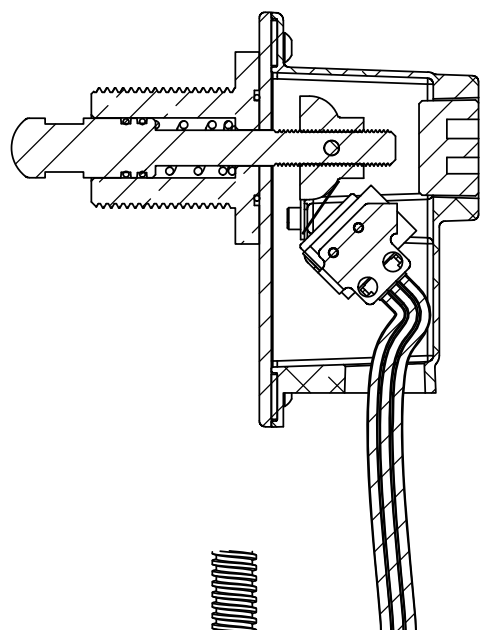
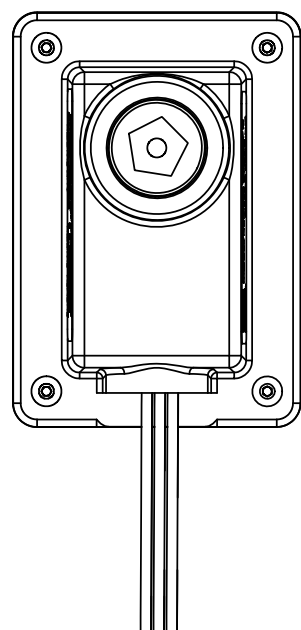

THIS SWITCH AVAILABLE ON
3",4",6",8",10",12" SIZES

NEMA 4X

CAUTION

PRIOR TO INSTALLATION OF SUPERVISORY SWITCHES IN FIRE PROTECTION SYSTEMS REFER TO THE FOLLOWING STANDARDS:
NFPA 13: STANDARD FOR THE INSTALLATION OF SPRINKLER SYSTEMS
NFPA 25: INSPECTION, TESTING, MAINTENANCE OF WATER BASED FIRE PROTECTION SYSTEMS
NFPA 70: NATIONAL ELECTRICAL CODE
NFPA 72: NATIONAL FIRE ALARM CODE
CSA C22.1 NO.1 CANADIAN ELECTRICAL CODE, PART 1, SAFETY STANDARD FOR ELECTRICAL INSTALLATIONS SECTION 32
CAN/ULC-S524, STANDARD FOR INSTALLATION OF FIRE ALARM SYSTEMS

KENNEDY VALVE
DIVISION OF MCWANE, INC.
TECHNICAL SERVICE MANUAL
KVOS-2 SWITCH

ISSUED		DRAWING
BY	DATE	32451-01
JEB	8/21/17	(PAGE 1/2)



KVOS-2
KSRW/KSRWHP/KSFV/KSFVHP FOR INDOOR & OUTDOOR USE



WARNING:

METALLIC CONDUIT REQUIRED BY NEC FOR PROPER GROUNDING
CONDUIT JOINT MUST BE SEALED WITH CONDUCTIVE SEALANT.
INSTALL SWITCH IN ACCORDANCE WITH "NATIONAL ELECTRICAL CODE" AND/OR LOCAL ORDINANCES.
WIRING METHODS SHALL BE IN ACCORDANCE WITH CSA C22.1, CANADIAN ELECTRICAL CODE, PART 1, SAFETY STANDARD FOR ELECTRICAL INSTALLATIONS, SECTION 32
AND CAN/ULC-S524, STANDARD FOR INSTALLATION OF FIRE ALARM SYSTEMS
ASSURE ALL DEVICES ARE PROPERLY GROUNDING.

KVOS-2 FOR KSRW/KSRWHP 3"-12"

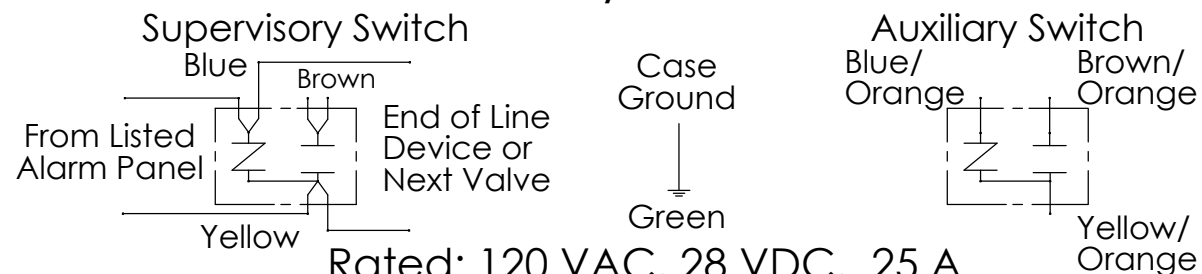

Rated: 120 VAC, 28 VDC, .25 A

Wiring Notes: Connection to power limited circuitry is required.
Auxiliary switch is for supplemental use only, and shall not be used for fire alarm signaling applications
Switches are checked at factory, check continuity with valve fully open, switches activate within two turns from open

FIELD SERVICE OF INSTALLED SWITCH:

Field repair by other than factory personnel is not recommended. Consult factory before attempting any repairs. Tamper resistant tools are required. Limited internal parts available.
All replacement parts must be obtained from the manufacturer to assure proper operation of the valve and to maintain agency approval of the device.

FIELD INSTALLATION OF SWITCH:

1. CLOSE VALVE
 2. REMOVE WHEEL NUT WITH APPROPRIATE OPEN END WRENCH
 3. REMOVE HANDWHEEL
 4. SCREW SWITCH UNIT INTO TAPPED HOLE UNTIL BUSHING IS FLUSH WITH THE INSIDE OF THE YOKE
 5. TIGHTEN NUT AGAINST YOKE WITH AN OPEN END WRENCH TO 50 FTLBS MIN
 6. RE-INSTALL HANDWHEEL
 7. OPEN VALVE UNTIL TRIP ARM IS HALFWAY INTO THE GROOVE.
 8. REMOVE SECURITY PLUG
 9. USING 9/16" SOCKET WITH EXTENSION, BACK OFF ADJUSTMENT NUT UNTIL IT DEPRESSES SWITCH TAB; COUNTERACT ROTATION OF THE TRIP ARM WITH A 9/16" OPEN END WRENCH. THERE WILL BE TWO CLICKS. AT THIS POINT THERE SHOULD BE CONTINUITY THROUGH THE BROWN AND YELLOW LEADS. THE BROWN WITH ORANGE STRIPE AND YELLOW WITH ORANGE STRIPE LEADS MUST HAVE CONTINUITY AS WELL.
 10. OPEN VALVE FULLY, ENSURING THE TRIP ARM IS SEATED IN THE GROOVE. AT THIS POINT THE BLUE TO YELLOW LEADS AND BLUE/ORANGE TO YELLOW/ORANGE LEADS MUST HAVE CONTINUITY. IF BOTH SWITCHES AREN'T IN UNISON, FURTHER ADJUSTMENTS MUST BE MADE.
- NOTE: THE SWITCH MUST BE INSTALLED IN SUCH A MANNER SO THAT CLOSING 20% OF THE VALVE OR A MAXIMUM OF 4 REVOLUTIONS WILL CAUSE THE SWITCH TO CHANGE STATUS; VERIFY THIS AFTER SETTING LIMITS

KENNEDY VALVE
DIVISION OF MCWANE, INC.
TECHNICAL SERVICE MANUAL
KVOS-2 SWITCH

ISSUED		DRAWING
BY	DATE	32451-01
JEB	8/21/17	(PAGE 2/2)

